

# SKF Transmission chains





# Contents

## A Introduction

Standards and compliance .....	3
Chain parts .....	14

## B Selection and procedures

Chain selection procedure and design guidelines .....	10
Power rating tables .....	15
Basic Selection procedure .....	28

## C Product range

SKF American standard chains .....	33
SKF BS European standard chains .....	35
SKF Xtra Corrosion Resistant Chains .....	37
SKF Xtra Strength Chains .....	46
SKF Xtra Strength H and BH chains .....	47
SKF Xtra Strength BH Series .....	49
SKF Xtra Strength SH Chains .....	50
SKF Xtra Strength SPH Chains .....	52
SKF Xtra Strength SHH Chains .....	54
SKF Engineered drive chains .....	56
SKF Xtra Performance SLR Chains .....	57
SKF Side Bow Chains .....	59
SKF Hollow Pin Chains .....	61
SKF Straight Side Plate Chains .....	63
SKF Double Pitch Roller Chains .....	67

SKF Agricultural chains .....	70
SKF Silent Chains .....	72
SKF PIV Chains (Self forming tooth chains) .....	75
SKF Oil Field Chains .....	76
SKF Leaf Chains .....	78

## D Useful information

Chain chemical resistance comparison .....	85
Useful formulae for power transmission .....	88

## E Maintenance systems

SKF Lubrication Systems .....	91
Reduced maintenance .....	92
Design optimization .....	93

## F SKF the knowledge engineering company

SKF the knowledge engineering company .....	94
---	----

# Standards and compliance

SKF chains are manufactured in state of the art facilities with tight quality controls. All products conform to ISO standards and other industrial standards like ANSI, BS, DIN and JIS. SKF Oil Field Chains are American Petroleum Institute (API) approved and each box carries the API monogram. SKF automotive chains meets the ISO/TS16949 Quality Assurance System technical specification. This specification aligns American (QS-9000), German (VDA6.1), French (EAQF) and the Italian (AVSQ) automotive quality system standards within the global automotive industry.

All SKF chains, with the exception of stainless steel, can accommodate temperatures from  $-20$  to  $150$  °C. Stainless steel chains have a temperature range of  $-20$  to  $400$  °C. For temperatures exceeding above mentioned values, alternative lubricants should be used. Note: For temperatures above  $200$  °C and below  $-20$  °C, breaking load values are reduced. Apart from stainless steel chains also other anti-corrosion treatments and special coatings are readily available upon request.



## Raw material

The raw materials used to manufacture each component of the chain must meet very stringent specifications. As a result, there are very tight controls over all incoming materials. These controls range from carefully selecting the steel mills to regular material audits. Every shipment of raw material must include a laboratory report certifying the material composition of the steel. In addition, samples are thoroughly tested to confirm that the steel meets all specifications.

After stringent inspections, the steel undergoes the pre-production process, which starts with annealing. Annealing softens and relieves any stresses in the steel. From there, the material goes through a multi-stage rolling process to provide a consistent plate thickness. Other pre-production steps depend on the type of material and how the material will be used.



*Continuous rolling machine to achieve uniform thickness of plate material*



# The manufacturing process

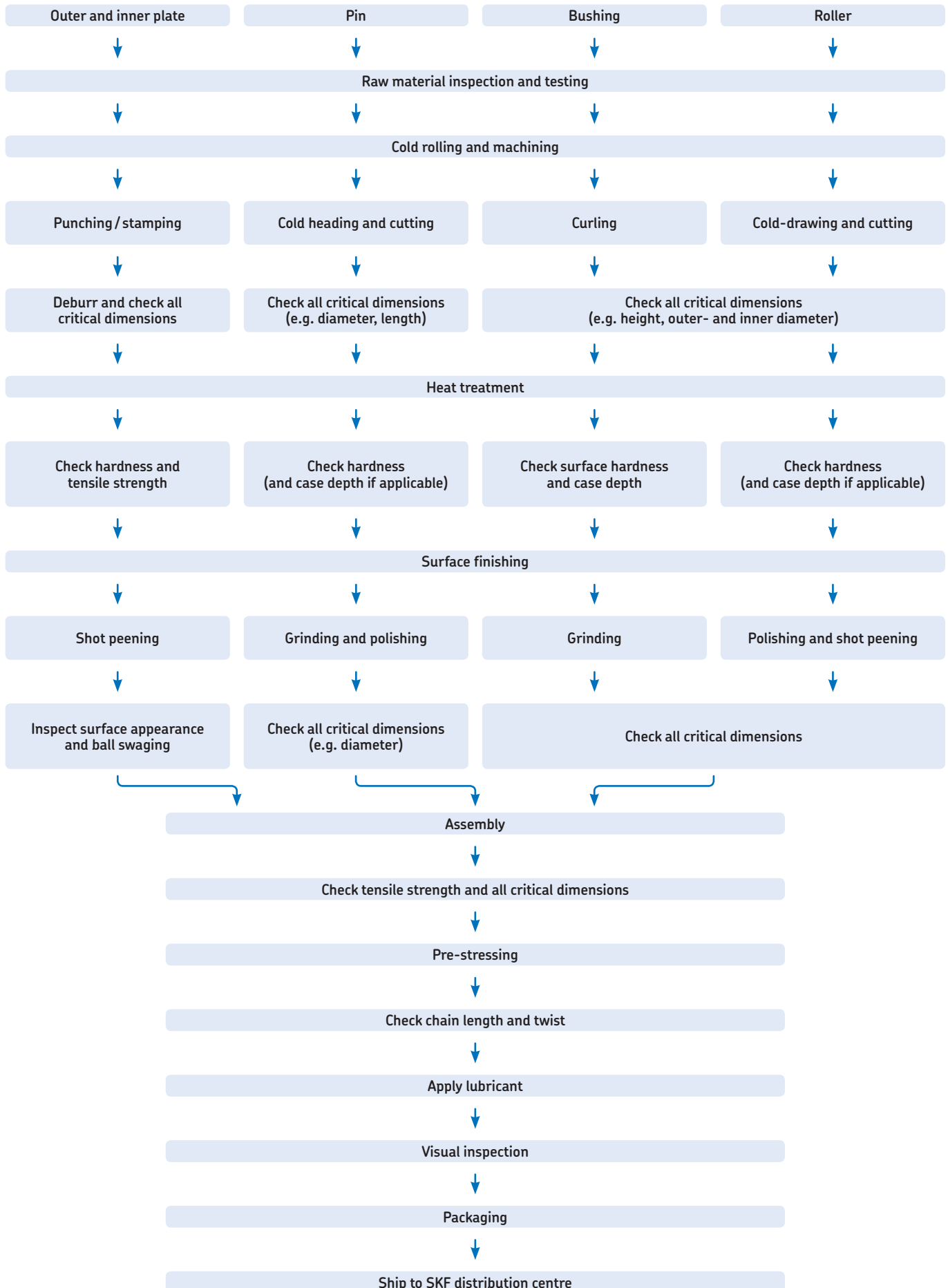

# Chain parts

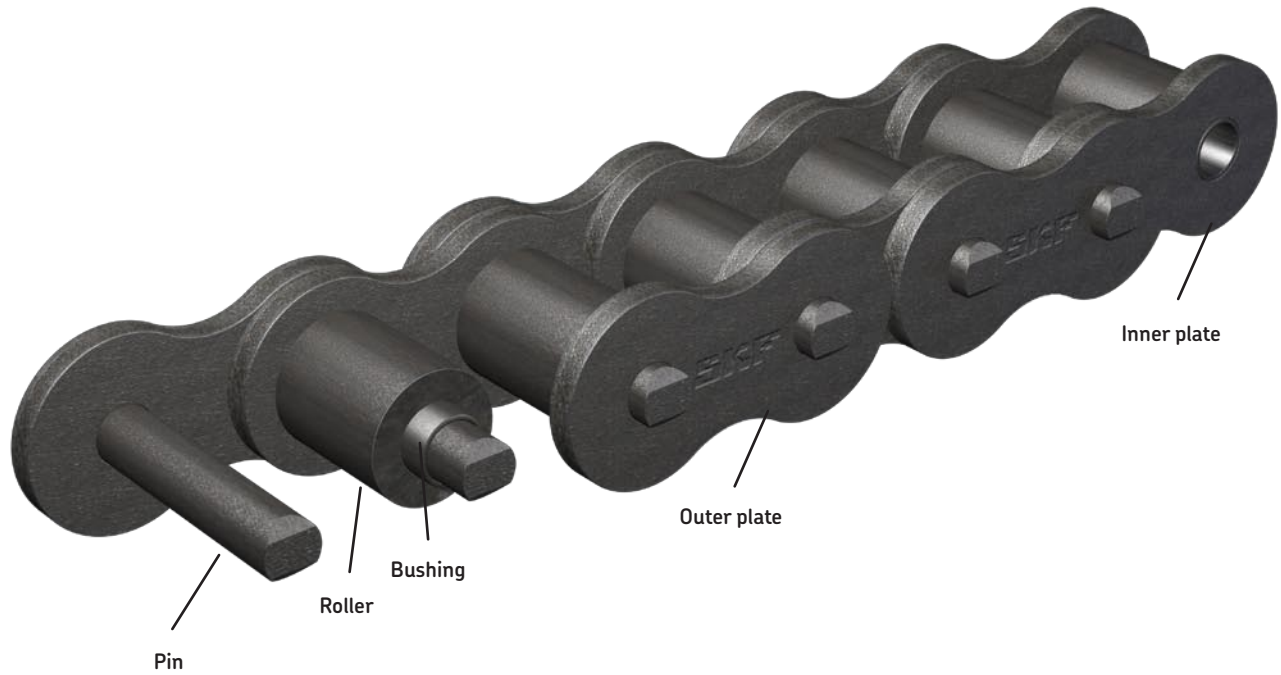

## Link plates (inner and outer plates)

The shape of inner and outer plates on SKF chains have been adopted to a wider waist link plate design. This provides an increase in fatigue strength. By subjecting the raw material to a series of cold rolling processes and stringent thickness controls, the plates achieve uniform thicknesses which are critical to a smooth running chain. The plates endurance and strength is fully optimized via thru-hardening, shot peening and an aperture ball-burnishing process.

*Shot peening improves fatigue strength and crack resistance*



*Furnaces for heat treatment process*



## Pins

Pins are made from alloy steel that has been case hardened in rotary furnaces. These furnaces provide an even heat for a consistent and uniform case depth, which helps to resist damage from shock loads and provide maximum wear resistance.



*Rotary furnaces used in the heat treatment process provide a uniform heat for a more consistent and uniform result*



*Pins are precision ground to enhance wear resistance and increase chain service life*

## Bushings

Cold rolling provides a uniform wall thickness which is extremely important in achieving a precise and consistent pitch. Precision curling units offer a uniform bushing roundness, inside and out, for an optimum bushing-link plate fit. The case hardening process provides the bushing with a wear-resistant case and a tough, impact resistant core. After heat treatment, the bushings are precision ground to improve service life.

*Automated assembly process rejects parts that do not meet, fit or tolerance specifications*

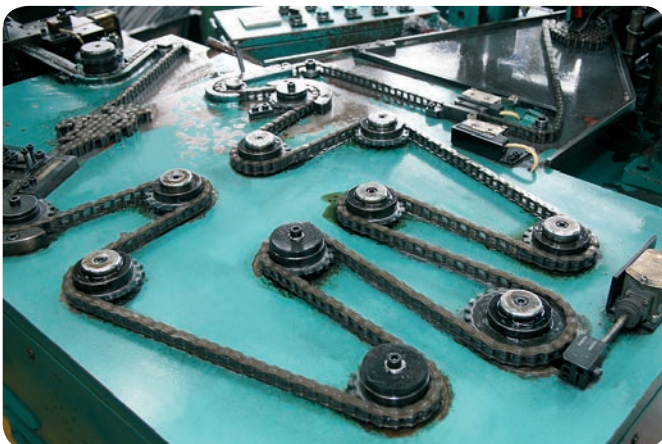

*Conveyor furnace line used for roller and bushing heat treatment, e.g. carbon-nitriding*





## Rollers

SKF chains use solid rollers that are cold-drawn from bar stock to improve fatigue strength and resist the damaging effects of shock loads. All rollers go through a hardening process to improve wear resistance and increase service life. To reduce cracking, the rollers undergo shot peening which significantly improves fatigue strength.



*Parts manufacturing lines*

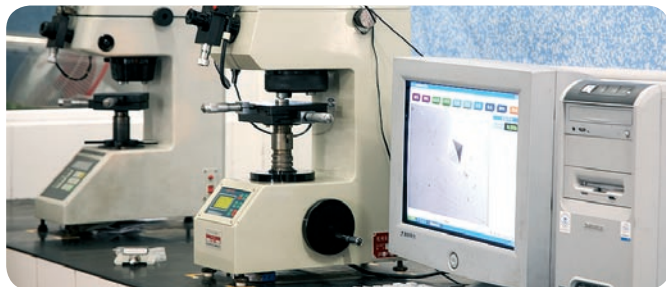

*Microhardness testing equipment, where batch tests are done, to ensure hardness is within specification*

## Assembly process

The automated assembly process rejects parts that do not meet, fit or tolerance specifications, giving SKF chains a precisely spaced pitch and a near perfect fit. Every part and process is subject to tight quality controls with frequent checks to conform to tolerances and standards.

The assembled chains are then pre-stressed. This running-in of the chain not only avoids elongation, but it also improves the chain's fatigue resistance.

The final lubrication process provides SKF chains the lubricant they need for initial start-up. The lubricant also protects the chain against corrosion to significantly prolong shelf life.

*Pre-lubrication product line*



*Pre-stressing after final assembly*



# Connecting links

These links are used to connect two ends of a chain together. Both the spring clip and cotter pin type can be disassembled and replaced easily. The riveted type provides a very strong link, and has a similar fatigue strength as the other links in the chain.

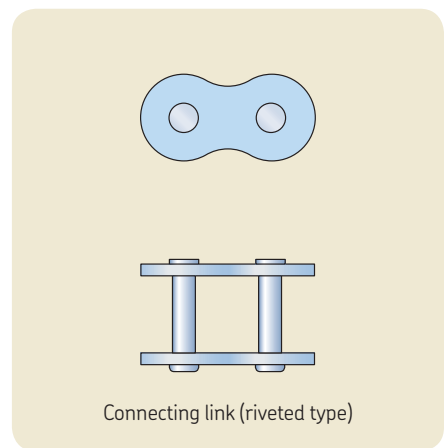
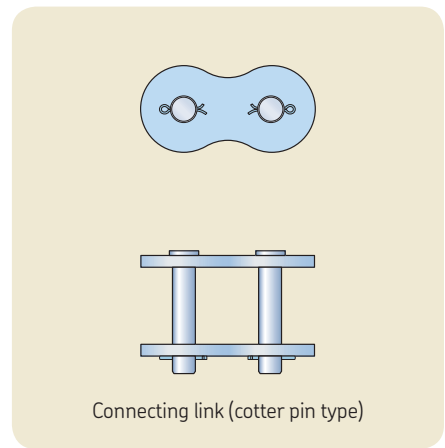
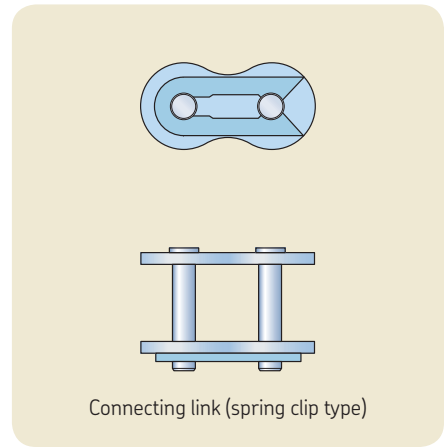

Table 1

## Standard connecting links

Chain number ANSI			BS/ISO			
25-1	25-2	25-3	04B-1	04B-2	04B-3	Spring clip
			05B-1	05B-2	05B-3	Spring clip
35-1	35-2	35-3	06B-1	06B-2	06B-3	Spring clip
40-1	40-2	40-3	08B-1	08B-2	08B-3	Spring clip
50-1	50-2	50-3	10B-1	10B-2	10B-3	Spring clip
60-1	60-2	60-3	12B-1	12B-2	12B-3	Spring clip
80-1	80-2	80-3	16B-1	16B-2	16B-3	Spring clip
100-1	100-2	100-2	20B-1	20B-2	20B-3	Cotter pin
120-1	120-2	120-3	24B-1	24B-2	24B-3	Cotter pin
140-1	140-2	140-3	28B-1	28B-2	28B-3	Cotter pin
160-1	160-2	160-3	32B-1	32B-2	32B-3	Cotter pin
180-1	180-2	180-3	36B-1	36B-2	36B-3	Cotter pin
200-1	200-2	200-3	40B-1	40B-2	40B-3	Cotter pin
240-1	240-2	240-3	48B-1	48B-2	48B-3	Cotter pin

Connecting link riveted type is also available on request.

## Offset links

Offset links are used when an odd number of pitches are required in a chain. These links consist of two cranked plates which are press fitted onto a bush and roller. The wide end is placed over the last link in the chain and a connecting pin is installed and secured with a split pin.

**NOTE:** It should be noted the use of the offset link de-rates the capacity of the standard transmission chain, particularly the use of the one pitch off-set link.

Off-set links should avoided on higher speed applications, shock-loaded drives, and only be used where set centres are required, and no other option is available.

**Off-set links are NOT available for any of the heavy or super-heavy series chains such as the H, SH, SHH or SPH range.**

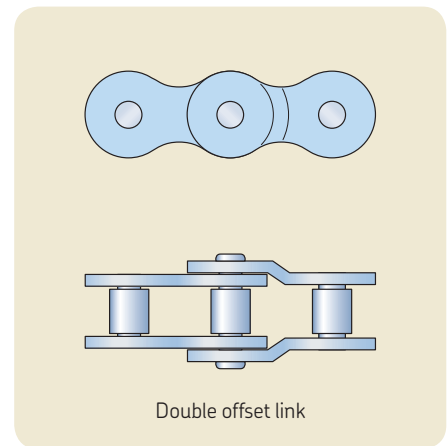
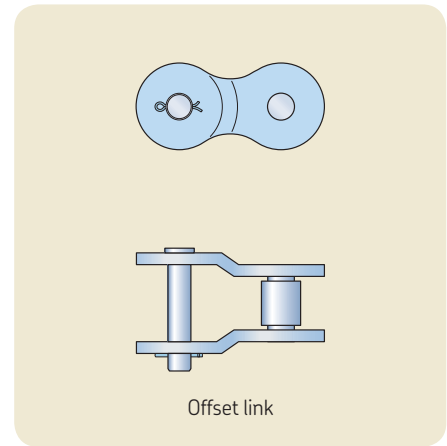

# Chain selection procedure and design guidelines

The following is a general guideline for the selection of roller transmission chains, whether DIN/BS or ANSI.

## Information required

For correct selection, as much of the following information should be supplied

- Power (kW or HP) or torque
- Type of prime mover (e.g. electric motor, I.C. engine etc..)
- Type of DriveN equipment
  - Hours of operation
  - Type of loading / environment / duty etc
- Speeds (dR and dN) or one speed and the ratio
- Centre distance (nominal) usually between 30 – 80 pitches

- Application service factor ( $F_a$ ) Takes into account the application, type of prime mover duty etc
- Speed factor ( $F_n$ ) Compensates for the chains' speed → **Table 2**
- Temperature factor ( $F_t$ ) Compensates for the ambient temperature (up to 250 °C)

Additionally, the service factor should be increased by a factor of 1.05 to 1.1 for each of the following conditions

- Frequent stop / starts
- Insufficient lubrication
- Short centres (usually regarded as less than 30 pitches)
- More than two sprocket system
- Reversing torque / load
- High load variations

## Service factors

### Application service factor ( $F_a$ )

For transmission chain there may be a number of service factors that need to be applied. These may be:

Table 1

Application service factor ( $F_a$ )		Type of prime mover		
Load classification	Driven equipment	Electric motor or turbine	Internal combustion engine > 6 cylinders, with flywheel, or hydraulic coupling	Internal combustion engine < 6 cylinders, with NO flywheel, or hydraulic coupling
Uniform load (U)	Agitators; centrifugal blowers; generators, centrifugal pumps; Uniformly loaded belt conveyor, lightly loaded chain conveyors	1.0	1.0	1.2
Moderate shock (M)	Centrifugal compressors,; kilns and dryers; conveyors and elevators with intermittent, medium load fluctuations; Dryers; Pulverisers; machinery with moderate pulsating loads (machine tools paper, textiles)	1.3	1.2	1.4
Heavy shock (H)	Press, construction and mining equipment; reciprocating machinery, (compressors, reciprocating feeders, oil well rigs) rubber mixers, roll lines, machinery with heavy shock or reversing torques	1.5	1.4	1.7 – 1.9

# Temperature factor ( $F_T$ )

(NOTE: for STANDARD Transmission chains only)

When chains are operating in the temperature conditions below, their respective ratings or capacity to perform must be re-rated. The power ratings shown in the following selection tables must be multiplied by the  $F_T$  factor below → **Table 3**.

## Sprocket selection

In selecting sprockets in a chain drive, there are a number of considerations that need to be taken into account for good life / wear. The ideal small tooth sprocket is 25 Tooth, as the tangential forces are minimal and the chain articulation around the sprocket is smooth with little or no chordal or polygon effect. (see note 4.3 below).

However, often space, and cost make this impractical. As a result the 19 Tooth is a good compromise, as it still offers good articulation and is more cost-effective. On a 1:1 drive, the best combination is again 25T... so the total drive system has the best number of teeth in contact – i.e. 50. Where practicable, drives should have this number in contact.

- The number of teeth should include an odd number (for even wear over all teeth in the system)... e.g. 19, 21, 23, 25T...
- The smaller sprocket should be at least 19 tooth, if possible
- Using sprockets below 19T has several effects on the chain
  - Poor articulation about the sprocket (this is extenuated even further as the number of teeth reduce)
  - High loading on the sprocket tooth and subsequently in the pin / bush / roller bearing area, ultimately limiting the chains' capacity
  - Increased overhung load on the bearings of the driver / driven.
  - Reduced kW capacity
  - Reduced life
  - High point loads on the sprocket pitch line from transfer of the bushing / roller loads
- Where space (diameter) is an issue consideration can be given to using multi-strands of chain (keeping in mind the resultant overhung loads (FR) will still apply, but the chain capacity will increase)

## Preferred sprocket sizes

The BS/DIN and ANSI (US) standards have “preferred sizes” for sprocket teeth (→ **Table 4**).

## Sprocket selection parameters

The following points need to be considered when initial selection is done:

Table 2

Speed of chain	Speed factor	Speed of chain	Speed factor
m/s	$F_n$	m/s	$F_n$
Less than 0.17	1.0	>0.5 – < 0.67	1.3
>0.17 and <0.33	1.1	>0.67 – < 0.83	1.4
>0.33 and < 0.5	1.2	>0.83 – <1.17	1.6

Table 3

Temperature factor ( $F_T$ )	
Temperature range °C	$F_T$ factor
–40 °C to –30 °C	Not suitable
–30 °C to –20 °C	0.25
–20 °C to –10 °C	0.33
–10 °C to +150 °C	1.00
150 °C to +200 °C	0.75
+200 °C to +250 °C	0.5
> +250 °C	Refer SKFPTP

Table 4

### BS / DIN preferred sprockets

11	12	13	15	17	19	20	21	23	25	27	30
38	45	57	76	95	114						

### ANSI preferred sprockets

9	10	11	12	13	14	15	16	17	18	19	20
28	30	32	35	36	40	42	45	48	52	54	60
70	72	80	84	96	112						

- Those listed in italics should only be used when necessary.
- Not all sprocket sizes are available in all pitches, or multiple strand options (e.g. duplex, triplex...).
- Other intermediate sizes, while “non-preferred”, are available from SK PTP. See pages 163–236 of the **General Catalogue 11015EN (II)**

## Sprocket type

A reduced number of teeth in the drive results in very high pressure in the pin / bush / roller zones. It is particularly noticeable at the point of roller contact with the driver (smaller) sprocket tooth. In severe conditions, it may result over time, in tooth hooking or even roller cracking.

If the circumstances mean larger sprockets are impractical, the consideration must be given to the sprocket teeth being hardened, preferably by induction hardening, as the control of depth and heat distribution is generally better.

## Hardened teeth

The use of hardened tooth sprockets should be considered in the following conditions:

- Low speeds, heavily loaded drives
- Large ratio drives
- Abrasive or corrosive conditions

Using hardened tooth sprockets over 25T has little or no effect on the drive, as the chain roller sprocket pressure is no longer as much of an issue for correctly sized chains. Additionally, the chordal effect may be considered to be virtually zero.

The hardening of the tooth (typically between 35-50 HRC\*), will give better sprocket resistance to roller impact and the high point loads of the chain running on smaller sprockets. This should reduce sprocket tooth “hooking” and give better sprocket wear over the life of the chain. (\*Hardening ranges above and below this mid-range (SKF reference IH2) are available on request only... e.g. IH1: 30-45HRC or IH3, 40-55HRC), subject to charges.

**NOTE: The SKF stock range of Type B sprockets, up to and including 25T will ALL be HARDENED tooth (to SKF Ref IH2) – as STANDARD.**

## Chain pitch

Use the smallest chain pitch that will meet the application. If a single strand has insufficient capacity, then the use of multi-strand chains should be considered (see Multi-strand chains at page 13). The higher the chain speed, the smaller the recommended pitch.

## Drive life

A chain is usually selected for 15,000 hours, based on normal selection procedure. The test graphs of chain power ratings are based on a 19T to 57T (3:1 ratio), with centres of between 30-80 pitches. This is based on a well selected, lubricated, and maintained chain with correct tension.

- Tentative selection should be based on the 19T sprocket. However sprocket teeth as low as 11T may be used at very slow speeds. At high speeds it is recommended to use up to 25T for smooth operation
- When using sprockets below  $z = 19T$ , the chain capacity is “re-rated” as illustrated in the following power tables. As a guideline only, typical values for the Tooth Factor (F2) are shown below in → **Table 5:**

From the above it can be seen that using (say) a 15T sprocket will reduce the chains’ power ratings by approximately 40%... and a 12 tooth by up to 65%. Conversely, using sprockets over 19T will increase the chains’ capacity.

(NOTE: These factors are **for reference only**, and have already been incorporated in the following power rating tables)

Table 5

### Sprocket Correction Factors

No. teeth Z	Tooth Factor F2	No. teeth Z	Tooth Factor F2	No. teeth Z	Tooth Factor F2
23	1.22	17	0.90	12	0.35
21	1.11	15	0.60	11	0.30
19	1.00	13	0.40	10	NR <sup>A</sup>

## Chordal or polygon effect

When the chain articulates about the sprocket, the pitch line of the chain forms a series of tangential lines between adjacent sprocket teeth... whether they be an odd or even number. A correctly selected and sized sprocket will ensure these lines actually closely follow the sprocket pitch line... hence the larger the better.

As the number of teeth reduces, the tangent angles can become extreme, with the chain effectively moving about a series of angles. The forces exerted by the chain become very high, leading to poor efficiency and high wear due to high friction between the loaded points of the pin / bush and roller.

Additionally, the chain, trying to overcome the tangential forces will start to ride up on the sprocket tooth... this riding up the tooth

alters the radius the chain should be running at. The result is the chain linear speed changes.... In extreme cases the chain seems to be going fast then slow... this effect is called "hunting" and is a direct result of the chordal (or tangential) effect.

## Chain wrap and drive ratio

In general the minimum wrap on the small sprocket should be no less than 120°, to ensure smooth operation. Additionally single reduction drives should be limited to a maximum of 7:1. If larger reductions are required, a two stage or double reduction is recommended.

## Multiple strand drives

The use of MULTIPLE strand chain will increase the power capacity (and drive width) while maintaining the same diameters, and should be considered if space is an issue, or if centre distances are small (less than 30 pitches).

Typical power multipliers are shown in **Table 6**, (applicable for BS / DIN or ANSI chains):

Table 6

### Multiple strand factor

No. strands	Multiplier K2	No. strands 1	Multiplier K2
1	1.0	4	3.3.
2	1.7	5	3.9
3	2.5	6	4.6

<sup>1</sup> BS or DIN chain are only available up to "triplex" or 3 strand configuration, unless against special demand (MTO)

Diagram 1

### Diagram of chordal or polygon effect

$$\text{Percentage variation of chain speed} = \frac{V_2 - V_1}{V_2} \cdot 100$$

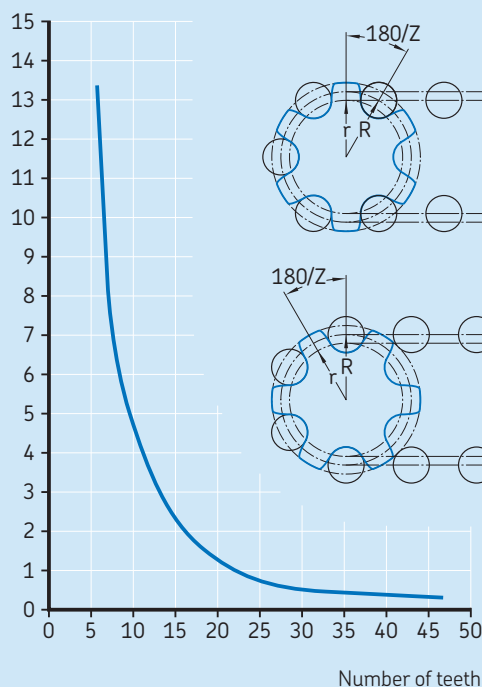

Maximum speed of the chain

$$V_1 = \frac{2 \cdot \pi \cdot r \cdot n}{12} \text{ [m/min]}$$

Maximum speed of the chain

$$V_2 = \frac{2 \cdot \pi \cdot R \cdot n}{12} \text{ [m/min]}$$

# Lubrication

On the power rating tables, the foot of each table shows a “Lubrication Type”. This is the recommended method of lubrication at that operating speed. The types referred to are shown in **Table 7** below:

**Table 7**

Lubrication methods		
Type	Lubrication method	Description
<b>Type I</b> (Low speed)	Manual lubrication Drip feed lubrication	Oil is applied manually by brush or oil-can Via a drip system in a case, oil is fed via the sump to drip nozzles at a pre-determined rate
<b>Type II</b> (Low- Medium speed)	Oil bath Disc lubrication	In a leak proof casing, the chain dips into the sump reservoir by about 13–17mm. In a leak proof casing, a disc or flinger supplies oil to the chain, which operates above the oil level.
<b>Type III</b> (High speed)	Pump lubrication	In a leak proof casing oil is pumped directly onto the chain links. The oil is circulated usually via an external filter / cooling system.

**Relative speed range for lubrication tables**  
**Type I:** Low speed is considered to be less than 60% of the maximum permissible chain speed.  
**Type II:** Low-Medium speed is between 60% and 80% of the maximum permissible chain speed.  
**Type III:** High speed is when the chain is operating over 80% of the permissible chain speed.  
 In general, the larger the chain pitch, the lower the permissible speed range. If higher speeds are required, consider using multi-strand chains.

# Chain length

If not already determined, the actual chain length may be calculated from the following formulae and the ‘K’ factor table (→ **Table 8**). The shaft centres should be between 30 and 80 pitches.

Where:

- L = Chain length (in pitches)
- Z<sub>1</sub> = No. of teeth of small sprocket
- Z<sub>2</sub> = No. of teeth of large sprocket
- C = Shaft centres (in pitches)
- K = A constant, determined from (Z<sub>2</sub>-Z<sub>1</sub>), in **Table 8**

$$L = \frac{Z_2 + Z_1}{2} + 2C + \frac{K}{C}$$

**Table 8**

'K' Factors													
Z <sub>1</sub> -Z <sub>2</sub>	K	Z <sub>1</sub> -Z <sub>2</sub>	K	Z <sub>1</sub> -Z <sub>2</sub>	K	Z <sub>1</sub> -Z <sub>2</sub>	K	Z <sub>1</sub> -Z <sub>2</sub>	K	Z <sub>1</sub> -Z <sub>2</sub>	K	Z <sub>1</sub> -Z <sub>2</sub>	K
1	0,0	11,00	3,06	21,00	11,17	31,00	24,34	41,00	42,58	51,00	65,88	61	94,25
2	0,1	12,00	3,65	22,00	12,26	32,00	25,94	42,00	44,68	52,00	68,49	62	97,37
3	0,2	13,00	4,28	23,00	13,40	33,00	27,58	43,00	46,84	53,00	71,15	63	100,54
4	0,4	14,00	4,96	24,00	14,59	34,00	29,28	44,00	49,04	54,00	73,86	64	103,75
5	0,6	15,00	5,70	25,00	15,83	35,00	31,03	45,00	51,29	55,00	76,62	65	107,02
6	0,9	16,00	6,48	26,00	17,12	36,00	32,83	46,00	53,60	56,00	79,44	66	110,34
7	1,2	17,00	7,32	27,00	18,47	37,00	34,68	47,00	55,95	57,00	82,30	67	113,71
8	1,6	18,00	8,21	28,00	19,86	38,00	36,58	48,00	58,36	58,00	85,21	68	117,13
9	2,1	19,00	9,14	29,00	21,30	39,00	38,53	49,00	60,82	59,00	88,17	69	120,6
10	2,5	20,00	10,13	30,00	22,80	40,00	40,53	50,00	63,33	60,00	91,19	70	124,12
71	127,7	81,00	166,19	91,00	209,76	101,00	258,39	111,00	312,09	121,00	370,86	131	434,69
72	131,3	82,00	170,32	92,00	214,40	102,00	263,54	112,00	317,74	122,00	377,02	132	441,36
73	135,0	83,00	174,50	93,00	219,08	103,00	268,73	113,00	323,44	123,00	383,22	133	448,07
74	138,7	84,00	178,73	94,00	223,82	104,00	273,97	114,00	329,19	124,00	389,48	134	454,83
75	142,5	85,00	183,01	95,00	228,61	105,00	279,27	115,00	334,99	125,00	395,79	135	461,64
76	146,3	86,00	187,34	96,00	233,44	106,00	284,67	116,00	340,84	126,00	402,14	136	468,51
77	150,2	87,00	191,73	97,00	238,33	107,00	290,01	117,00	346,75	127,00	408,55	137	475,42
78	154,1	88,00	196,16	98,00	243,27	108,00	295,45	118,00	352,70	128,00	415,01	138	482,39
79	158,1	89,00	200,64	99,00	248,26	109,00	300,95	119,00	358,70	129,00	421,52	139	489,41
80	162,1	90,00	205,18	100,00	253,30	110,00	306,50	120,00	364,76	130,00	428,08	140	496,47



# Power rating tables

The following Power Rating Tables (**pages 16 to 31**) are based on the following general parameters:

- Normal ambient conditions
- Power rating is for a single strand chain
- Service Factor (Fs) for the values shown is 1.0.
- Lubrication is appropriate for the speed shown
- The shafts are parallel, and well aligned
- Any load variation is minimal

Any variation to the above conditions will require the application of the relevant Service factor, with regards to application, no. of chain strands, and temperature.

# Power Rating Tables (kW) – BS / DIN Chains

Table 9a

## 06B-1; (9.53 mm Pitch) Power ratings in kilowatt (European standard)

No of teeth	Pitch circle Dia.	rpm of small (faster) sprocket z <sub>1</sub>																
		Z	mm	25	50	75	100	200	400	500	750	1 000	1 200	1 440	1 750	2 000	2 250	2 500
13	<b>39,80</b>		0,05	0,10	0,14	0,18	0,35	0,67	0,76	1,14	1,49	1,73	2,05	2,67	2,95	3,30	3,55	4,31
15	<b>45,81</b>		0,06	0,11	0,15	0,19	0,37	0,71	0,80	1,22	1,59	1,83	2,17	2,82	3,12	3,50	3,76	4,57
17	<b>51,84</b>		0,07	0,13	0,19	0,23	0,46	0,87	0,99	1,48	1,95	2,25	2,68	3,47	3,83	4,30	4,62	5,61
19	<b>57,87</b>		0,08	0,15	0,22	0,27	0,54	1,01	1,15	1,73	2,27	2,62	3,11	4,04	4,46	5,00	5,38	6,53
21	<b>63,91</b>		0,09	0,18	0,24	0,30	0,59	1,11	1,27	1,91	2,49	2,87	3,42	4,44	4,90	5,50	5,91	7,18
23	<b>69,95</b>		0,10	0,19	0,26	0,32	0,64	1,22	1,38	2,08	2,72	3,14	3,73	4,84	5,36	5,99	6,45	7,84
25	<b>76,00</b>		0,10	0,21	0,28	0,35	0,70	1,31	1,50	2,25	2,95	3,40	4,05	5,25	5,80	6,50	6,99	9,21
Lubrication method			TYPE 1						TYPE 2									

Table 9b

## 08B-1; (12.70 mm Pitch) power ratings in kilowatt (European standard)

No of teeth	Pitch circle Dia.	rpm of small (faster) sprocket z <sub>1</sub>																
		Z	mm	25	50	75	100	200	400	500	750	1 000	1 200	1 440	1 800	2 000	2 250	2 400
13	<b>53,07</b>		0,16	0,24	0,43	0,59	0,82	1,55	2,18	3,24	4,06	4,14	4,56	5,14	6,59	5,33	3,34	2,39
15	<b>61,08</b>		0,18	0,28	0,45	0,62	0,96	1,80	2,32	3,44	4,31	4,84	5,28	6,38	6,99	5,64	4,14	2,97
17	<b>69,12</b>		0,22	0,32	0,56	0,76	1,10	2,06	2,84	4,22	5,28	5,53	5,94	7,69	8,59	6,93	5,00	3,57
19	<b>77,16</b>		0,25	0,36	0,65	0,89	1,25	2,33	3,31	4,91	6,15	6,24	6,91	9,01	9,99	8,06	5,90	4,22
21	<b>85,21</b>		0,27	0,39	0,71	0,98	1,39	2,60	3,64	5,41	6,77	6,96	7,60	10,04	10,99	8,87	6,86	4,91
23	<b>93,27</b>		0,30	0,43	0,78	1,06	1,52	2,85	3,97	5,89	7,37	7,67	8,29	11,07	11,99	9,68	7,86	5,62
25	<b>101,33</b>		0,32	0,48	0,84	1,15	1,67	3,12	4,30	6,39	7,99	8,39	8,98	12,10	12,99	10,49	8,93	6,38
Lubrication method			TYPE 1						TYPE 2						TYPE 3			

Table 9c

## 10B-1; (15.875 mm Pitch) Power ratings in kilowatt (European standard)

No of teeth	Pitch circle Dia.	rpm of small (faster) sprocket z <sub>1</sub>																
		Z	mm	25	50	75	100	200	300	400	500	750	1 000	1 200	1 500	1 800	2 100	2 400
13	<b>66,34</b>		0,25	0,43	0,66	0,82	1,60	2,19	2,81	3,48	4,94	6,47	7,68	7,81	5,84	4,62	3,79	3,17
15	<b>76,35</b>		0,27	0,52	0,70	0,95	1,70	2,58	2,99	4,06	5,24	6,86	9,01	9,70	7,24	5,73	4,70	3,93
17	<b>86,39</b>		0,33	0,59	0,85	1,09	2,08	2,94	3,67	4,64	6,44	8,43	10,22	11,67	8,76	6,91	5,67	4,76
19	<b>96,45</b>		0,38	0,66	1,00	1,23	2,42	3,32	4,26	5,23	7,49	9,80	11,59	13,82	10,38	8,16	6,70	5,61
21	<b>106,51</b>		0,42	0,74	1,10	1,38	2,67	3,69	4,69	5,84	8,24	10,77	12,88	15,79	12,02	9,45	7,79	6,55
23	<b>116,51</b>		0,45	0,81	1,19	1,51	2,90	4,08	5,12	6,42	8,98	11,75	14,16	17,33	13,82	10,82	8,93	7,49
25	<b>126,66</b>		0,49	0,90	1,30	1,67	3,15	4,46	5,54	7,03	9,73	12,73	15,63	18,97	15,63	12,36	10,12	8,50
Lubrication method			TYPE 1						TYPE 2						TYPE 3			

Refer multiple strand factor multiplier on **table 6, page 13**  
For requirements at faster speeds, or sprocket sizes contact SKF

# Power Rating Tables (kW) – BS / DIN Chains

Table 9d

## 12B-1; (19.05 mm Pitch) Power ratings in kilowatt (European standard)

No of teeth	Pitch circle Dia.	rpm of small (faster) sprocket z <sub>1</sub>																	
		Z	mm	25	50	75	100	200	300	400	500	750	1 000	1 200	1 440	1 800	2 000	2 200	2 400
13	<b>79,60</b>	0,39	0,64	1,09	1,18	2,21	3,57	4,59	5,04	8,12	10,27	10,48	8,31	5,73	4,86	4,21	3,70		
15	<b>91,62</b>	0,42	0,74	1,15	1,37	2,59	3,79	4,87	5,88	8,61	10,90	12,96	10,30	7,08	6,03	5,22	4,58		
17	<b>103,67</b>	0,52	0,84	1,42	1,58	2,97	4,66	5,98	6,74	10,58	13,38	14,94	12,54	8,58	7,27	6,30	5,53		
19	<b>115,74</b>	0,60	0,96	1,65	1,78	3,34	5,42	6,95	7,62	12,20	15,56	16,74	14,76	10,12	8,58	7,49	6,53		
21	<b>127,82</b>	0,66	1,07	1,81	1,98	3,73	5,96	7,65	8,45	13,52	17,12	18,72	17,08	11,76	9,96	8,67	7,62		
23	<b>139,90</b>	0,72	1,17	1,98	2,18	4,10	6,50	8,34	9,35	14,76	18,67	20,60	19,65	13,47	11,51	9,87	8,76		
25	<b>151,99</b>	0,77	1,29	2,14	2,39	4,49	7,05	9,04	10,22	15,99	20,23	22,58	22,23	15,27	12,96	11,25	9,87		
Lubrication method		TYPE 1					TYPE 2					TYPE 3							

Table 9e

## 16B-1; (25.4mm Pitch) Power ratings in kilowatt (European standard)

No of teeth	Pitch circle Dia.	rpm of small (faster) sprocket z <sub>1</sub>																	
		Z	mm	25	50	75	100	200	300	400	500	600	700	800	1 000	1 200	1 400	1 600	1 800
13	<b>106,14</b>	1,00	1,85	3,05	3,46	6,45	9,27	12,02	14,68	19,27	19,91	24,60	21,63	16,48	13,05	10,73	8,93		
15	<b>122,17</b>	1,15	2,16	3,23	4,04	7,53	10,82	14,08	17,17	20,45	23,26	26,09	26,78	20,42	16,22	13,21	11,07		
17	<b>138,23</b>	1,33	2,47	3,97	4,61	8,58	12,44	16,05	19,65	25,11	26,60	32,04	32,27	24,54	19,49	15,97	13,39		
19	<b>154,32</b>	1,49	2,79	4,61	5,21	9,70	13,99	18,11	22,15	29,20	30,05	37,27	38,19	29,10	23,09	18,88	15,79		
21	<b>170,42</b>	1,67	3,11	5,08	5,80	10,82	15,63	20,26	24,72	32,13	33,48	40,99	44,37	33,81	26,78	21,97	18,36		
23	<b>186,54</b>	1,83	3,43	5,54	6,41	11,93	17,17	22,32	27,21	35,04	36,90	44,72	50,81	28,41	29,80	25,15	21,12		
25	<b>202,66</b>	2,01	3,76	5,99	7,01	13,05	18,80	24,38	29,87	37,97	40,35	48,44	55,70	43,86	34,84	28,50	23,87		
Lubrication method		TYPE 1					TYPE 2					TYPE 3							

Table 9f

## 20B-1; (31.75 mm Pitch) Power ratings in kilowatt (European standard)

No of teeth	Pitch circle Dia.	rpm of small (faster) sprocket z <sub>1</sub>																	
		Z	mm	10	25	50	75	100	150	200	300	400	500	600	700	750	800	900	1 000
13	<b>132,67</b>	0,83	1,91	3,54	5,58	6,62	10,12	12,36	17,77	23,09	28,15	33,22	38,19	43,11	36,13	30,30	25,83		
15	<b>152,71</b>	0,97	2,22	4,14	5,92	7,73	10,74	14,42	20,78	26,96	32,88	38,80	44,55	45,72	44,81	37,51	32,01		
17	<b>172,79</b>	1,11	2,54	4,74	7,27	8,84	13,19	16,48	23,77	30,82	37,68	44,37	50,99	56,17	53,99	45,24	38,63		
19	<b>192,90</b>	1,26	2,86	5,35	8,46	9,96	15,35	18,62	26,78	34,76	42,49	50,04	57,61	65,31	63,86	53,48	45,66		
21	<b>213,03</b>	1,40	3,19	5,95	9,30	11,07	16,88	20,78	29,87	38,71	47,30	55,70	64,04	71,84	72,18	62,14	53,05		
23	<b>233,17</b>	1,55	3,52	6,52	10,15	12,28	18,42	22,84	32,96	42,66	52,19	61,54	70,64	78,37	79,65	71,25	60,85		
25	<b>253,32</b>	1,69	3,85	6,85	10,99	13,39	19,95	25,06	36,05	46,69	57,08	67,29	77,33	84,90	87,55	80,77	68,93		
Lubrication method		TYPE 1					TYPE 2					TYPE 3							

Refer multiple strand factor multiplier on **table 6, page 13**  
For requirements at faster speeds, or sprocket sizes contact SKF

# Power Rating Tables (kW) – BS / DIN Chains

Table 9g

## 24B-1; (38.10 mm Pitch) Power ratings in kilowatt (European standard)

No of teeth	Pitch circle Dia.	rpm of small (faster) sprocket z <sub>1</sub>																
		Z	mm	10	25	50	75	100	150	200	250	300	400	500	600	700	800	900
13	159,20		1,69	3,85	7,18	10,39	13,39	19,23	25,06	30,43	36,05	46,78	57,08	67,38	61,20	49,26	41,89	35,87
15	183,25		1,97	4,49	8,38	11,02	15,71	22,58	29,18	32,27	42,05	54,41	66,52	78,36	71,59	62,14	52,02	44,47
17	207,35		2,26	5,14	9,61	13,54	17,94	25,75	33,39	39,64	48,07	62,40	76,30	90,13	91,85	74,85	62,65	53,56
19	231,48		2,54	5,79	10,82	15,75	20,17	29,10	37,60	46,10	54,33	70,30	85,83	101,28	108,15	88,40	74,24	63,26
21	255,63		2,83	6,46	12,02	17,32	22,48	32,36	41,97	50,72	60,51	78,36	96,13	113,30	125,32	103,00	85,83	73,56
23	279,80		3,12	7,13	13,31	18,90	24,80	35,71	46,35	55,32	66,77	86,70	106,43	124,45	143,35	117,60	98,70	84,28
25	303,99		3,42	7,81	14,50	20,48	27,21	39,14	50,65	59,94	72,95	94,42	115,88	135,62	157,08	133,90	112,45	95,28
Lubrication method			TYPE 1					TYPE 2					TYPE 3					

Table 9h

## 28B-1; (44.45 mm Pitch) Power ratings in kilowatt (European standard)

No of teeth	Pitch circle Dia.	rpm of small (faster) sprocket z <sub>1</sub>																
		Z	mm	10	25	50	75	100	125	150	200	250	300	350	400	450	500	550
13	185,74		2,63	5,99	11,25	14,97	20,94	22,82	30,05	38,96	47,64	55,96	64,38	72,53	80,68	89,27	97,00	87,55
15	213,79		3,06	7,00	13,05	15,87	24,46	24,21	35,10	45,50	55,62	65,49	75,37	84,98	94,42	103,85	113,30	108,15
17	241,91		3,52	8,00	14,94	19,50	27,89	29,74	40,17	52,02	63,52	75,11	86,70	97,00	108,15	129,60	129,60	129,60
19	270,06		3,96	9,01	16,48	22,67	31,42	34,58	45,32	58,79	72,10	84,20	97,00	109,00	121,88	145,92	145,92	145,92
21	298,24		4,41	10,12	18,72	24,94	35,02	38,04	50,47	65,23	79,83	94,42	108,15	121,88	135,62	163,95	163,95	175,95
23	326,44		4,87	11,15	20,68	27,20	38,63	41,49	55,80	72,10	88,40	103,85	118,45	134,75	149,35	179,40	179,40	193,98
25	354,65		5,33	12,18	22,66	29,47	42,41	44,95	60,95	78,97	97,00	113,30	130,47	147,63	163,95	204,28	204,28	212,00
Lubrication method			TYPE 1					TYPE 2					TYPE 3					

Table 9i

## 32B-1; (50.80 mm Pitch) Power ratings in kilowatt (European standard)

No of teeth	Pitch circle Dia.	rpm of small (faster) sprocket z <sub>1</sub>																
		Z	mm	10	25	50	75	100	125	150	175	200	225	250	300	350	400	450
13	212,27		3,47	8,03	14,85	21,30	27,55	32,46	40,09	45,13	51,32	56,79	62,83	73,98	85,15	96,13	103,96	116,73
15	244,33		4,04	9,35	17,25	22,59	32,19	34,42	46,27	47,86	59,92	60,24	73,39	86,70	99,57	112,45	110,26	137,33
17	276,46		4,64	10,56	19,75	27,75	36,82	42,29	52,96	58,81	68,67	74,01	83,95	99,57	113,30	128,75	135,47	157,08
19	308,64		5,22	12,02	22,32	32,27	41,54	49,17	59,66	68,38	77,43	86,06	94,42	111,58	128,75	145,05	157,52	177,68
21	340,84		5,81	13,31	24,80	35,49	46,35	54,09	66,52	75,22	86,70	94,67	105,58	124,45	142,48	161,37	173,27	197,42
23	373,07		6,42	14,76	27,38	38,73	51,07	59,01	73,39	82,06	95,28	103,27	115,88	137,33	157,93	177,68	189,03	218,02
25	405,32		7,02	16,14	30,05	41,95	55,88	63,92	80,34	88,90	103,85	111,88	127,90	150,20	172,53	193,98	204,84	235,18
Lubrication method			TYPE 1					TYPE 2					TYPE 3					

Refer multiple strand factor multiplier on table 6, page 13  
For requirements at faster speeds, or sprocket sizes contact SKF

# Power Rating Tables (kW) – BS / DIN Chains

Table 9j

## 40B-1; (63.5 mm Pitch) Power ratings in kilowatt (European standard)

No of teeth	Pitch circle Dia.	rpm of small (faster) sprocket z <sub>1</sub>																	
		Z	mm	5	10	15	20	30	40	50	60	80	100	150	200	250	300	350	400
13	265,34	3,22	5,98	8,63	11,17	16,07	20,89	25,55	30,02	38,90	47,71	68,69	88,81	108,27	127,72	137,03	121,80		
15	305,42	3,76	6,99	10,07	13,11	18,86	24,36	29,77	35,10	45,50	55,49	79,93	104,04	126,88	152,25	153,09	134,49		
17	345,58	4,29	8,00	11,59	14,97	21,49	27,91	34,18	40,17	52,02	63,52	91,35	119,26	144,64	167,48	165,78	144,64		
19	385,79	4,82	9,05	12,94	16,92	24,28	31,47	38,32	45,25	58,62	71,73	103,20	134,49	163,24	181,00	178,47	153,09		
21	426,05	5,40	10,07	14,46	18,78	26,98	35,02	42,80	50,42	65,39	79,93	115,88	148,87	182,70	210,61	189,47	159,86		
23	466,34	5,96	11,08	15,99	20,73	29,86	38,65	47,37	55,74	72,24	87,97	126,88	164,10	200,46	223,30	197,93	164,94		
25	506,65	6,52	12,18	17,51	22,66	32,56	42,30	51,59	60,90	78,92	97,27	138,72	180,16	219,92	235,15	206,38	169,17		
Lubrication method		TYPE 1					TYPE 2					TYPE 3							

Table 9k

## 48B-1; (76.2mm Pitch) Power ratings in kilowatt (European standard)

No of teeth	Pitch circle Dia.	rpm of small (faster) sprocket z <sub>1</sub>																	
		Z	mm	5	10	15	20	30	40	50	60	80	100	150	175	200	250	300	350
13	318,41	4,94	9,22	13,28	17,17	24,79	32,15	39,25	46,26	59,89	73,25	105,73	120,96	123,50	110,81	89,65	62,50		
15	366,50	5,77	10,74	15,48	20,12	28,93	37,47	45,85	53,97	69,95	85,43	123,50	142,10	138,72	122,64	98,12	65,55		
17	414,69	6,61	12,35	17,76	23,01	33,07	42,88	52,45	61,74	80,01	91,35	141,26	157,33	153,09	133,65	104,88	66,82		
19	462,96	7,44	13,88	20,05	25,96	37,30	48,39	59,12	69,70	90,51	104,04	159,02	171,71	165,78	143,80	109,95	66,23		
21	511,26	8,30	15,48	22,33	28,93	41,62	53,88	65,89	77,65	100,66	116,73	176,78	185,24	178,47	152,25	113,35	64,03		
23	599,61	9,14	17,08	24,61	31,89	45,93	59,46	72,75	85,43	110,81	135,33	195,39	197,93	189,47	159,86	115,88	60,06		
25	607,98	9,98	18,70	26,90	34,84	50,24	65,04	79,50	93,89	121,80	148,87	214,85	209,77	199,62	165,78	115,88	54,22		
Lubrication method		TYPE 1					TYPE 2					TYPE 3							

Refer multiple strand factor multiplier on table 6, page 13  
For requirements at faster speeds, or sprocket sizes contact SKF

# Power Rating Tables (kW) – ANSI Chains

Table 10a

## 35-1 (06C-1); (9.53 mm Pitch) Power ratings in kilowatt (ANSI standard)

No of teeth	Pitch circle Dia.	rpm ( $N_1$ ) of small (faster) sprocket $z_1$																	
		Z	mm	50	100	200	240	500	700	900	1 200	1 500	1 800	2 100	2 500	3 000	3 500	4 000	4 500
13	39,80	0,10	0,19	0,37	0,45	0,90	1,25	1,58	2,09	2,59	3,08	3,57	3,70	2,81	2,24	1,83	1,53		
15	45,81	0,11	0,22	0,43	0,51	1,04	1,43	1,83	2,41	2,98	3,55	4,12	4,59	3,49	2,77	2,27	1,90		
17	51,84	0,13	0,25	0,48	0,58	1,18	1,63	2,07	2,73	3,38	4,03	4,67	5,52	4,21	3,34	2,74	2,29		
19	57,87	0,14	0,28	0,54	0,65	1,31	1,82	2,31	3,05	3,77	4,50	5,22	6,17	4,98	3,95	3,23	2,71		
21	63,91	0,16	0,31	0,60	0,72	1,45	2,01	2,56	3,37	4,18	4,98	5,77	6,82	5,78	4,59	3,75	3,15		
23	69,95	0,17	0,34	0,66	0,79	1,60	2,20	2,80	3,69	4,57	5,45	6,32	7,47	6,62	5,26	4,30	3,60		
25	76,00	0,19	0,37	0,72	0,86	1,73	2,39	3,04	4,01	4,97	5,92	6,86	8,12	7,51	5,96	4,88	4,09		
Lubrication method		TYPE 1					TYPE 2					TYPE 3							

Table 10b

## 40-1 (08A-1); (12.70 mm Pitch) Power ratings in kilowatt (ANSI standard)

No of teeth	Pitch circle Dia.	rpm ( $N_1$ ) of small (faster) sprocket $z_1$																	
		Z	mm	25	50	100	180	200	300	500	700	900	1 000	1 200	1 400	1 600	1 800	2 500	3 000
13	53,07	0,12	0,23	0,46	0,80	0,89	1,31	2,13	2,95	3,74	4,15	4,94	5,73	5,33	4,47	2,73	2,08		
15	61,08	0,14	0,27	0,52	0,93	1,02	1,51	2,46	3,39	4,33	4,78	5,70	6,61	6,61	5,54	3,39	2,57		
17	69,12	0,16	0,31	0,60	1,04	1,16	1,71	2,79	3,85	4,90	5,42	6,46	7,49	7,97	6,68	4,09	3,11		
19	77,16	0,18	0,34	0,66	1,17	1,29	1,91	3,12	4,30	5,48	6,06	7,22	8,37	9,43	7,90	4,83	3,67		
21	85,21	0,19	0,38	0,73	1,29	1,42	2,11	3,44	4,75	6,05	6,70	7,97	9,25	10,52	9,18	5,61	4,27		
23	93,27	0,21	0,41	0,81	1,42	1,57	2,31	3,77	5,21	6,63	7,33	8,74	10,13	11,52	10,52	6,43	4,89		
25	101,33	0,23	0,45	0,87	1,54	1,70	2,51	4,10	5,66	7,21	7,97	9,50	11,01	12,52	11,92	7,28	5,54		
Lubrication method		TYPE 1					TYPE 2												

Table 10c

## 41-1 (083-1); (12.70 mm Pitch) Power ratings in kilowatt (ANSI standard)

No of teeth	Pitch circle Dia.	rpm of small (faster) sprocket $z_1$																	
		Z	mm	25	50	100	180	200	300	500	700	900	1 000	1 200	1 400	1 600	1 800	2 500	3 000
13	53,07	0,07	0,13	0,25	0,44	0,48	0,72	1,17	1,62	2,06	2,16	1,64	1,31	1,07	0,90	0,54	0,42		
15	61,08	0,07	0,15	0,29	0,51	0,56	0,83	1,35	1,87	2,38	2,63	2,04	1,62	1,32	1,11	0,68	0,51		
17	69,12	0,09	0,17	0,33	0,57	0,63	0,94	1,53	2,12	2,69	2,98	2,45	1,95	1,60	1,34	0,82	0,62		
19	77,16	0,10	0,19	0,37	0,64	0,71	1,05	1,72	2,36	3,01	3,33	2,90	2,31	1,89	1,58	0,96	0,73		
21	85,21	0,10	0,21	0,40	0,71	0,78	1,16	1,89	2,62	3,33	3,69	3,37	2,68	2,19	1,84	1,12	0,85		
23	93,27	0,12	0,22	0,44	0,78	0,86	1,27	2,07	2,86	3,65	4,04	3,86	3,07	2,51	2,10	1,28	0,98		
25	101,33	0,13	0,25	0,48	0,84	0,93	1,38	2,25	3,11	3,96	4,39	4,38	3,48	2,84	2,39	1,45	1,11		
Lubrication method		TYPE 1					TYPE 2												

For multiple strand ratings – Refer multiple strand factor multiplier on page.  
For requirements at faster speeds, or sprocket sizes contact SKF

# Power Rating Tables (kW) – ANSI Chains

Table 10d

## 50-1 (10A-1); (15.875 mm Pitch) Power ratings in kilowatt (ANSI standard)

No of teeth	Pitch circle Dia.	rpm of small (faster) sprocket z <sub>1</sub>																	
		Z	mm	10	25	50	100	140	200	300	500	700	900	1 200	1 500	1 800	2 100	2 500	3 000
13	<b>66,34</b>	0,10	0,23	0,46	0,89	1,22	1,72	2,54	4,15	5,73	7,29	9,61	7,03	5,34	4,24	3,27	2,48		
15	<b>76,35</b>	0,11	0,27	0,52	1,02	1,41	1,98	2,93	4,78	6,61	8,41	11,09	8,71	6,62	5,26	4,04	3,08		
17	<b>86,39</b>	0,13	0,31	0,60	1,16	1,60	2,25	3,32	5,42	7,49	9,53	12,57	10,50	7,99	6,34	4,89	3,72		
19	<b>96,45</b>	0,14	0,34	0,66	1,29	1,78	2,51	3,72	6,06	8,37	10,65	14,05	12,41	9,44	7,50	5,77	4,39		
21	<b>106,51</b>	0,16	0,38	0,73	1,43	1,98	2,78	4,10	6,70	9,25	11,78	15,52	14,43	10,97	8,71	6,71	5,10		
23	<b>116,59</b>	0,17	0,41	0,81	1,57	2,16	3,04	4,49	7,33	10,13	12,90	17,00	16,53	12,58	9,98	7,68	5,85		
25	<b>126,66</b>	0,19	0,45	0,87	1,70	2,35	3,31	4,89	7,97	11,02	14,02	18,48	18,73	14,26	11,31	8,71	6,62		
Lubrication method		TYPE 1					TYPE 2					TYPE 3							

Table 10e

## 60-1 (12A-1); (19.05 mm Pitch) Power ratings in kilowatt (ANSI standard)

No of teeth	Pitch circle Dia.	rpm of small (faster) sprocket z <sub>1</sub>																	
		Z	mm	10	25	50	100	120	200	400	600	800	1 000	1 200	1 400	1 800	2 000	2 500	3 000
13	<b>79,60</b>	0,16	0,40	0,78	1,52	1,81	2,95	5,75	7,12	11,19	13,86	11,36	9,01	6,18	5,28	3,77	2,87		
15	<b>91,62</b>	0,19	0,46	0,90	1,75	2,09	3,41	6,64	8,22	12,91	15,99	14,08	11,18	7,66	6,54	4,68	3,56		
17	<b>103,67</b>	0,22	0,52	1,02	1,98	2,36	3,86	7,52	9,32	14,64	18,13	16,99	13,48	9,25	7,89	5,65	4,30		
19	<b>115,74</b>	0,25	0,59	1,14	2,22	2,65	4,32	8,41	10,41	16,35	20,26	20,07	15,93	10,93	9,33	6,68	5,08		
21	<b>127,82</b>	0,27	0,65	1,26	2,45	2,92	4,77	9,30	11,51	18,08	22,39	23,32	18,51	12,70	10,84	7,76	5,90		
23	<b>139,90</b>	0,30	0,71	1,38	2,69	3,20	5,23	10,18	12,61	19,80	24,53	26,74	21,22	14,55	12,43	8,89	6,77		
25	<b>151,99</b>	0,32	0,78	1,50	2,92	3,48	5,68	11,06	13,70	21,52	26,66	30,30	24,04	16,49	14,08	10,08	7,66		
Lubrication method		TYPE 1					TYPE 2					TYPE 3							

Table 10f

## 60H-1; (19.05 mm Pitch) Power ratings in kilowatt (ANSI standard)

No of teeth	Pitch circle Dia.	rpm of small (faster) sprocket z <sub>1</sub>																	
		Z	mm	10	25	50	90	100	200	400	600	800	1 000	1 200	1 400	1 800	2 000	2 500	3 000
13	<b>79,60</b>	0,19	0,46	0,90	1,59	1,75	3,42	6,64	9,80	12,92	14,93	11,36	9,01	6,18	5,28	3,77	2,87		
15	<b>91,62</b>	0,22	0,54	1,04	1,83	2,02	3,94	7,66	11,31	14,91	18,47	14,08	11,18	7,66	6,54	4,68	3,56		
17	<b>103,67</b>	0,25	0,60	1,18	2,07	2,30	4,47	8,68	12,82	16,90	20,93	16,99	13,48	9,25	7,89	5,65	4,30		
19	<b>115,74</b>	0,28	0,68	1,32	2,32	2,57	4,99	9,71	14,33	18,89	23,39	20,07	15,93	10,93	9,33	6,68	5,08		
21	<b>127,82</b>	0,31	0,75	1,45	2,57	2,83	5,51	10,73	15,84	20,87	25,86	23,32	18,51	15,15	10,84	7,76	5,90		
23	<b>139,90</b>	0,34	0,82	1,60	2,80	3,10	6,04	11,75	17,34	22,86	28,33	26,74	21,22	14,55	12,43	8,89	6,77		
25	<b>151,99</b>	0,37	0,90	1,74	3,05	3,37	6,56	12,77	18,85	24,85	30,79	30,30	24,04	16,49	14,08	10,08	7,66		
Lubrication method		TYPE 1					TYPE 2					TYPE 3							

For multiple strand ratings – Refer multiple strand factor multiplier on page.  
For requirements at faster speeds, or sprocket sizes contact SKF

# Power Rating Tables (kW) – ANSI Chains

Table 10g

## 80-1 (16A-1); (25.4 mm Pitch) Power ratings in kilowatt (ANSI standard)

No of teeth	Pitch circle Dia.	rpm of small (faster) sprocket z <sub>1</sub>																	
		Z	mm	10	25	50	75	100	300	500	700	900	1 200	1 400	1 600	1 800	2 000	2 500	3 000
13	106,14	0,39	0,94	1,83	2,69	3,55	10,19	19,82	22,98	22,01	14,30	11,35	9,29	7,78	6,65	4,75	3,62		
15	122,17	0,45	1,08	2,10	3,10	4,10	11,76	19,20	26,52	27,29	17,72	14,06	11,51	9,65	8,24	5,89	4,48		
17	138,23	0,51	1,22	2,39	3,52	4,64	13,32	21,76	30,06	32,92	21,38	16,97	13,89	11,64	9,94	7,11	5,41		
19	154,32	0,57	1,37	2,66	3,94	5,18	14,89	24,32	33,59	38,90	25,27	20,05	16,41	13,76	11,74	8,40			
21	170,42	0,63	1,51	2,95	4,35	5,74	16,46	26,88	37,13	45,20	29,36	23,30	19,07	15,98	13,64	9,77			
23	186,54	0,69	1,66	3,23	4,77	6,28	18,03	29,44	40,66	51,76	33,65	26,71	21,86	18,31	15,64	11,19			
25	202,66	0,75	1,81	3,51	5,18	6,83	19,60	32,00	44,20	56,26	38,14	30,27	24,77	20,76	17,72	6,09			
Lubrication method		TYPE 1				TYPE 2				TYPE 3									

Table 10h

## 80H-1; (25.4 mm Pitch) Power ratings in kilowatt (ANSI standard)

No of teeth	Pitch circle Dia.	rpm of small (faster) sprocket z <sub>1</sub>																	
		Z	mm	10	25	50	70	100	300	500	700	900	1 200	1 400	1 600	1 800	2 000	2 500	3 000
13	106,14	0,43	1,04	2,04	2,81	3,96	11,38	18,59	25,68	22,01	14,30	11,35	9,29	7,78	6,65	4,75	3,62		
15	122,17	0,50	1,21	2,35	3,25	4,57	13,14	21,45	29,62	27,29	17,72	14,06	11,51	9,65	8,24	5,89	4,48		
17	138,23	0,57	1,37	2,66	3,69	5,18	14,88	24,31	33,58	32,92	21,38	16,97	13,89	11,64	9,94	7,11	5,41		
19	154,32	0,63	1,53	2,98	4,12	5,80	16,64	27,17	37,52	38,90	25,27	20,05	16,41	13,76	11,74	8,40			
21	170,42	0,70	1,69	3,29	4,55	6,41	18,39	30,03	41,48	45,20	29,36	23,30	19,07	15,98	13,64				
23	186,54	0,77	1,85	3,60	4,98	7,01	20,14	32,89	45,42	51,81	33,65	26,71	21,86	18,31	15,64				
25	202,66	0,84	2,01	3,92	5,42	7,62	21,90	35,75	49,38	58,71	38,14	30,27	24,77	20,76	17,72				
Lubrication method		TYPE 1				TYPE 2				TYPE 3									

Table 10i

## 100-1 (20A-1); (31.75 mm Pitch) Power ratings in kilowatt (ANSI standard)

No of teeth	Pitch circle Dia.	rpm of small (faster) sprocket z <sub>1</sub>																	
		Z	mm	10	25	50	71	100	150	200	400	600	800	1 000	1 200	1 400	1 600	1 800	2 000
13	132,67	0,75	1,80	3,49	4,89	6,80	10,03	13,23	25,72	37,96	31,41	22,47	17,10	13,56	11,10	9,30	7,94		
15	152,71	0,86	2,07	4,04	5,65	7,84	11,58	15,26	29,68	43,81	38,93	27,85	21,19	16,81	13,76	11,53	9,85		
17	172,79	0,98	2,35	4,57	6,40	8,89	13,12	17,29	33,64	49,65	46,96	33,61	25,57	20,28	16,61	13,91	11,88		
19	192,90	1,09	2,63	5,11	7,15	9,94	14,67	19,33	37,60	55,49	55,49	39,70	30,21	23,97	19,62	16,44	14,04		
21	213,03	1,20	2,90	5,65	7,91	10,98	16,21	21,37	41,56	61,33	64,48	46,14	35,10	27,85	22,80	19,11	16,32		
23	233,17	1,32	3,18	6,18	8,65	12,03	17,75	23,39	45,51	67,17	73,91	52,88	40,23	31,92	26,13	21,90	18,69		
25	253,32	1,43	3,45	6,72	9,41	13,07	19,29	25,43	49,47	73,01	83,75	59,93	45,59	36,17	29,61	24,81	0,00		
Lubrication method		TYPE 1				TYPE 2				TYPE 3									

For multiple strand ratings – Refer multiple strand factor multiplier on page.  
For requirements at faster speeds, or sprocket sizes contact SKF



# Power Rating Tables (kW) – ANSI Chains

Table 10j

## 100H-1; (31.75 mm Pitch) Power ratings in kilowatt (ANSI standard)

No of teeth	Pitch circle Dia.	rpm of small (faster) sprocket z <sub>1</sub>																	
		Z	mm	10	25	50	58	100	200	300	400	500	600	700	800	900	1 000	1 200	1 800
13	132,67	0,81	1,97	3,83	4,42	7,45	14,49	21,38	28,18	34,91	41,59	38,37	31,41	26,32	22,47	17,10	9,30		
15	152,71	0,94	2,27	4,42	5,10	8,59	16,72	24,67	32,52	40,28	47,99	47,56	38,93	32,62	27,85	21,19	11,53		
17	172,79	1,07	2,57	5,01	5,77	9,74	18,94	27,96	36,85	45,66	54,39	57,37	46,96	39,36	33,61	25,57	13,91		
19	192,90	1,19	2,88	5,60	6,45	10,88	21,17	31,25	41,19	51,03	60,78	67,80	55,49	46,51	39,70	30,21	16,44		
21	213,03	1,32	3,18	6,18	7,13	12,03	23,40	34,54	45,52	56,40	67,18	77,90	64,48	54,03	46,14	35,10	19,11		
23	233,17	1,45	3,48	6,77	7,81	13,17	25,63	37,83	49,86	61,77	73,59	85,32	73,91	61,93	52,88	40,23	21,90		
25	253,32	1,57	3,78	7,36	8,49	14,32	27,86	41,12	54,20	67,14	79,99	92,74	83,75	70,19	59,93	45,59	22,14		
Lubrication method		TYPE 1				TYPE 2						TYPE 3							

Table 10k

## 120-1 (24A-1); (38.10 mm Pitch) Power ratings in kilowatt (ANSI standard)

No of teeth	Pitch circle Dia.	rpm of small (faster) sprocket z <sub>1</sub>																	
		Z	mm	10	25	50	75	100	150	200	300	400	500	600	700	800	900	1 000	1 200
13	159,20	1,26	3,04	5,90	8,71	11,48	16,94	22,33	32,96	43,44	53,82	55,94	44,39	36,34	30,45	26,00	19,78		
15	183,25	1,45	3,50	6,81	10,05	13,25	19,55	25,77	38,03	50,12	62,10	69,34	55,02	45,04	37,74	32,23	24,51		
17	207,35	1,65	3,97	7,76	11,39	15,01	22,16	29,20	43,10	56,81	70,38	83,66	66,39	54,34	45,54	38,88	29,58		
19	231,48	1,84	4,43	8,62	12,73	16,78	24,76	32,64	48,17	63,49	78,66	93,71	78,44	64,20	53,81	45,94	34,95		
21	255,63	2,04	4,90	9,53	14,07	18,55	27,37	36,08	53,24	70,18	86,94	103,57	91,15	74,60	62,52	53,38	40,61		
23	279,80	2,23	5,36	10,44	15,40	20,31	29,97	39,51	58,31	76,85	95,22	113,43	104,47	85,51	71,66	61,19	46,54		
25	303,99	2,42	5,83	11,35	16,75	22,07	32,58	42,95	63,38	83,54	103,50	123,29	118,39	96,91	81,21	69,34	52,75		
Lubrication method		TYPE 1				TYPE 2						TYPE 3							

Table 10l

## 120H-1; (38.10 mm Pitch) Power ratings in kilowatt (ANSI standard)

No of teeth	Pitch circle Dia.	rpm of small (faster) sprocket z <sub>1</sub>																	
		Z	mm	10	25	50	75	100	150	200	300	400	500	600	700	800	900	1 000	1 200
13	159,20	1,36	3,27	6,37	9,41	12,40	18,30	24,12	35,60	46,92	58,13	55,94	44,39	36,34	30,45	26,00	19,78		
15	183,25	1,57	3,78	7,36	10,85	14,31	21,11	27,83	41,07	54,14	67,07	69,34	55,02	45,04	37,74	32,23	24,51		
17	207,35	1,78	4,28	8,33	12,30	16,21	23,93	31,54	46,55	59,90	76,02	83,66	66,39	54,34	45,54	38,88	29,58		
19	231,48	1,98	4,79	9,32	13,75	18,12	26,74	35,26	52,03	68,58	84,96	98,85	78,44	64,20	53,81	45,94	34,95		
21	255,63	2,19	5,29	10,29	15,20	20,03	29,56	38,96	57,50	75,79	93,90	111,86	91,15	74,60	62,52	53,38	40,61		
23	279,80	2,40	5,80	11,28	16,64	21,94	32,38	42,67	62,98	83,01	102,84	122,52	104,47	85,51	71,66	61,19	46,54		
25	303,99	2,61	6,30	12,26	18,09	23,84	35,19	46,39	68,46	90,24	111,79	133,17	118,39	96,91	81,21	69,34	52,75		
Lubrication method		TYPE 1				TYPE 2						TYPE 3							

For multiple strand ratings – Refer multiple strand factor multiplier on page.  
For requirements at faster speeds, or sprocket sizes contact SKF

# Power Rating Tables (kW) – ANSI Chains

Table 10m

## 140-1 (28A-1); (44.45 mm Pitch) Power ratings in kilowatt (ANSI standard)

No of teeth	Pitch circle Dia.	rpm of small (faster) sprocket z <sub>1</sub>																	
		Z	mm	5	10	25	50	75	100	150	200	300	400	500	600	700	800	900	1 000
13	185,74	1,00	1,95	4,69	9,13	13,47	17,76	26,21	34,55	51,00	67,21	83,19	63,28	50,22	41,10	34,45	29,41		
15	213,79	1,16	2,25	5,42	10,53	15,55	20,49	30,24	39,87	58,84	77,55	96,08	78,44	62,25	50,94	42,69	36,46		
17	241,91	1,31	2,54	6,14	11,94	17,62	23,22	34,28	45,19	66,68	87,89	108,89	94,64	75,10	61,47	51,51	43,98		
19	270,06	1,46	2,85	6,86	13,35	14,11	19,69	25,96	38,31	50,50	74,53	98,23	121,70	111,82	72,63	60,87	51,97		
21	298,24	1,62	3,15	7,58	14,75	21,77	28,69	42,34	55,82	82,37	108,57	134,51	129,93	103,11	84,39	70,73	60,39		
23	326,44	1,77	3,45	8,30	16,15	23,84	31,45	46,38	61,13	90,22	118,91	147,32	148,86	118,19	96,73	81,07	69,21		
25	354,65	1,92	3,74	9,03	17,56	25,92	34,16	50,41	66,45	98,06	129,26	160,14	168,78	133,93	109,62	91,87	78,44		
Lubrication method		TYPE 1					TYPE 2					TYPE 3							

Table 10n

## 140H-1; (44.45 mm Pitch) Power ratings in kilowatt (ANSI standard)

No of teeth	Pitch circle Dia.	rpm of small (faster) sprocket z <sub>1</sub>																	
		Z	mm	5	10	25	50	75	100	150	200	300	400	500	600	700	800	900	1 000
13	185,74	1,07	2,08	5,02	9,76	14,41	18,99	28,03	36,94	54,52	71,85	83,19	63,28	50,22	41,10	34,45	29,41		
15	213,79	1,24	2,40	5,79	11,26	16,62	21,91	32,34	42,62	62,90	82,91	102,72	78,44	62,25	50,94	42,69	36,46		
17	241,91	1,40	2,72	6,56	12,76	18,84	24,83	36,65	48,30	71,29	93,97	116,41	94,64	75,10	61,47	51,51	43,98		
19	270,06	1,57	3,04	7,33	14,26	21,05	27,75	40,96	53,99	79,68	105,02	130,11	111,82	88,74	72,63	60,87	51,97		
21	298,24	1,73	3,36	8,11	15,77	23,28	30,68	45,27	59,67	88,07	116,08	143,81	129,93	103,11	84,39	70,73	60,39		
23	326,44	1,89	3,69	8,88	17,27	25,49	33,59	49,58	65,35	96,45	127,13	157,50	148,93	118,19	96,73	81,07	69,21		
25	354,65	2,06	4,01	9,65	18,77	27,71	36,52	53,89	71,03	104,84	138,19	171,20	168,78	133,93	109,62	91,87	78,44		
Lubrication method		TYPE 1					TYPE 2					TYPE 3							

Table 10o

## 160-1 (32A-1); (50.80 mm Pitch) Power ratings in kilowatt (ANSI standard)

No of teeth	Pitch circle Dia.	rpm of small (faster) sprocket z <sub>1</sub>																	
		Z	mm	5	10	25	50	75	100	150	200	300	400	500	600	700	800	900	1 000
13	212,27	1,45	2,83	6,81	13,25	19,55	25,77	38,03	50,12	73,98	97,51	92,57	70,42	55,88	45,74	38,33	32,73		
15	244,33	1,68	3,26	7,86	15,29	22,56	29,74	43,88	57,84	85,36	112,51	114,73	87,28	69,27	56,69	47,51	40,57		
17	276,46	1,90	3,69	8,91	17,32	25,57	33,70	49,73	65,55	96,74	127,51	138,43	105,31	83,57	68,40	57,32	48,95		
19	308,64	2,13	4,13	9,95	19,36	28,57	37,66	55,58	73,26	108,13	142,52	163,56	124,43	98,74	80,81	67,73	57,83		
21	340,84	2,35	4,57	11,00	21,40	31,58	41,63	61,43	80,97	119,51	157,52	190,06	144,58	114,73	93,91	78,70	67,19		
23	373,07	2,57	5,00	12,05	23,44	34,58	45,59	67,28	88,68	130,89	172,52	213,74	165,72	131,51	107,64	90,21	77,02		
25	405,32	2,79	5,43	13,09	25,48	37,60	49,56	73,14	96,40	142,27	187,52	232,32	187,80	149,03	121,98	102,22	87,28		
Lubrication method		TYPE 1					TYPE 2					TYPE 3							

For multiple strand ratings – Refer multiple strand factor multiplier on page.  
For requirements at faster speeds, or sprocket sizes contact SKF

# Power Rating Tables (kW) – ANSI Chains

Table 10p

## 160H-1; (50.80 mm Pitch) Power ratings in kilowatt (ANSI standard)

No of teeth	Pitch circle Dia.	rpm of small (faster) sprocket z <sub>1</sub>																	
		Z	mm	5	10	25	50	75	100	150	200	300	400	500	600	700	800	900	1 000
13	212,27	1,54	3,00	7,22	14,05	20,74	27,33	40,34	53,17	78,47	103,43	92,57	70,42	55,88	45,74	38,33	32,73		
15	244,33	1,78	3,46	8,33	16,21	23,92	31,53	46,54	61,35	90,54	119,35	114,73	87,28	69,27	56,69	47,51	40,57		
17	276,46	2,01	3,92	9,44	18,37	27,12	35,74	52,75	69,53	102,61	135,26	138,43	105,31	83,57	68,40	57,32	48,95		
19	308,64	2,25	4,38	10,56	20,54	30,31	39,95	58,96	77,71	114,69	151,17	163,56	124,43	98,74	80,81	67,73	57,83		
21	340,84	2,49	4,84	11,67	22,69	33,50	44,15	65,16	85,89	126,76	167,08	190,06	144,58	114,73	93,91	78,70	67,19		
23	373,07	2,72	5,30	12,78	24,86	36,69	48,36	71,37	94,07	138,83	182,99	217,85	165,72	131,51	107,64	90,21	77,02		
25	405,32	2,96	5,77	13,89	27,02	39,87	52,56	77,58	102,25	150,90	198,91	246,42	187,80	149,03	121,98	102,22	87,28		
Lubrication method		TYPE 1				TYPE 2						TYPE 3							

Table 10q

## 180-1 ( 36A-1); (57.15 mm Pitch) Power ratings in kilowatt (ANSI standard)

No of teeth	Pitch circle Dia.	rpm of small (faster) sprocket z <sub>1</sub>																	
		Z	mm	2	5	10	25	43	50	75	100	150	200	300	400	500	600	700	800
13	238,81	0,84	2,01	3,90	9,40	15,82	18,29	27,00	35,58	52,51	69,21	102,15	134,65	101,72	77,38	61,40	50,26		
15	274,88	0,96	2,31	4,50	10,85	18,26	21,10	31,15	41,05	60,59	79,87	117,87	155,36	126,07	95,91	76,11	62,29		
17	311,02	1,09	2,63	5,10	12,29	20,69	23,92	35,30	46,53	68,67	90,51	133,59	176,07	152,11	115,71	91,83	75,16		
19	347,22	1,22	2,93	5,70	13,74	23,13	26,74	39,41	52,00	76,75	101,16	149,30	196,79	179,73	136,72	108,50	88,80		
21	383,45	1,34	3,24	6,30	15,19	25,57	29,55	43,60	57,48	84,83	111,81	165,02	217,50	208,84	158,87	126,07	103,19		
23	419,71	1,47	3,55	6,90	16,64	28,00	32,36	47,76	62,95	92,91	122,46	180,73	238,22	239,37	182,10	144,50	118,27		
25	455,98	1,60	3,86	7,50	18,08	30,43	35,17	51,91	68,42	100,99	133,11	196,44	258,94	271,26	206,36	163,75	134,03		
Lubrication method		TYPE 1				TYPE 2						TYPE 3							

Table 10r

## 180H-1; (57.15 mm Pitch) Power ratings in kilowatt (ANSI standard)

No of teeth	Pitch circle Dia.	rpm of small (faster) sprocket z <sub>1</sub>																	
		Z	mm	2	5	10	25	37	50	75	100	150	200	300	400	500	600	700	800
13	238,81	0,88	2,11	4,11	9,91	14,44	19,28	28,45	37,51	55,35	72,96	107,68	141,93	101,72	77,38	61,40	50,26		
15	274,88	1,01	2,44	4,74	11,44	16,58	22,25	32,83	43,28	63,87	84,19	124,25	163,76	126,07	95,91	76,11	62,29		
17	311,02	1,15	2,79	5,38	12,96	18,88	25,21	37,21	49,04	72,38	95,41	140,81	185,60	152,11	115,71	91,83	75,16		
19	347,22	1,28	3,09	6,01	14,49	21,10	28,18	41,59	54,82	80,90	106,63	157,38	207,43	179,73	136,72	108,50	88,80		
21	383,45	1,42	3,42	6,64	16,01	23,33	31,15	45,97	60,58	89,42	117,86	173,94	229,27	208,84	158,87	126,07	103,19		
23	419,71	1,55	3,74	7,27	17,53	25,55	34,11	50,34	66,36	97,93	129,08	190,51	251,10	239,37	182,10	144,50	118,27		
25	455,98	1,69	4,07	7,91	19,06	27,77	37,08	54,72	72,12	106,45	140,31	207,07	272,94	271,26	206,36	163,75	134,03		
Lubrication method		TYPE 1				TYPE 2						TYPE 3							

For multiple strand ratings – Refer multiple strand factor multiplier on page.  
For requirements at faster speeds, or sprocket sizes contact SKF

# Power Rating Tables (kW) – ANSI Chains

Table 10s

## 200-1 (40A-1); (63.5 mm Pitch) Power ratings in kilowatt (ANSI standard)

No of teeth	Pitch circle Dia.	rpm of small (faster) sprocket z <sub>1</sub>																	
		Z	mm	2	5	10	25	40	50	75	100	150	200	250	300	400	500	600	700
13	265,34	1,10	2,66	5,18	12,48	19,60	24,28	35,84	47,24	69,72	91,90	113,85	135,63	154,65	110,66	84,19	66,80		
15	305,42	1,28	3,07	5,98	14,41	22,62	28,02	41,35	54,51	80,45	106,04	131,36	156,50	191,68	137,16	104,34	82,80		
17	345,58	1,45	3,48	6,77	16,32	25,63	31,76	46,87	61,78	91,18	120,17	148,88	177,36	231,27	165,49	125,89	99,90		
19	385,79	1,61	3,89	7,57	18,25	28,65	35,49	52,38	69,04	101,90	134,31	166,40	198,23	261,28	195,53	148,74	118,04		
21	426,05	1,78	4,30	8,37	20,16	31,67	39,23	57,90	76,31	112,62	148,45	183,91	219,09	288,78	227,20	172,84	137,16		
23	466,34	1,95	4,71	9,16	22,09	34,68	42,96	63,41	83,58	123,35	163,34	201,43	239,96	316,28	260,42	198,11	157,21		
25	506,65	2,13	5,12	9,96	24,01	37,70	46,70	68,92	90,85	134,08	176,73	218,94	260,82	343,79	295,12	224,50	178,16		
Lubrication method		TYPE 1					TYPE 2					TYPE 3							

Table 10t

## 200H-1; (63.5 mm Pitch) Power ratings in kilowatt (ANSI standard)

No of teeth	Pitch circle Dia.	rpm of small (faster) sprocket z <sub>1</sub>																	
		Z	mm	2	5	10	25	33	50	75	100	150	200	250	300	400	500	600	700
13	265,34	1,21	2,92	5,68	13,67	17,85	26,60	39,26	51,75	76,38	100,67	124,72	148,57	154,65	110,66	84,19	66,80		
15	305,42	1,40	3,36	6,55	15,78	20,60	30,70	45,30	59,71	88,12	116,16	143,90	171,43	191,68	137,16	104,34	82,80		
17	345,58	1,58	3,81	7,42	17,88	23,34	34,79	51,34	67,67	99,87	131,65	163,09	194,29	231,27	165,49	125,89	99,90		
19	385,79	1,77	4,26	8,30	19,99	26,09	38,88	57,38	75,64	111,62	147,13	182,29	217,15	273,26	195,53	148,74	118,04		
21	426,05	1,95	4,71	9,17	22,09	28,84	42,97	63,42	83,60	123,37	162,62	201,47	240,00	317,53	227,20	172,84	137,16		
23	466,34	2,14	5,16	10,04	24,19	31,59	47,07	69,46	91,56	135,13	178,11	220,66	262,86	346,47	260,42	198,11	157,21		
25	506,65	2,33	5,61	10,91	26,30	34,33	51,16	75,50	99,52	146,88	193,59	239,85	285,72	376,60	295,12	224,50	178,16		
Lubrication method		TYPE 1					TYPE 2					TYPE 3							

Table 10u

## 240-1 (48A-1); (76.2 mm Pitch) Power ratings in kilowatt (ANSI standard)

No of teeth	Pitch circle Dia.	rpm of small (faster) sprocket z <sub>1</sub>																	
		Z	mm	2	5	10	25	36	50	75	100	150	200	250	300	400	500	600	700
13	318,41	1,78	4,29	8,34	20,10	28,53	39,11	57,73	76,08	112,30	148,01	183,37	218,44	178,94	128,04	97,41	77,29		
15	366,50	2,05	4,95	9,62	23,20	32,92	45,13	66,60	87,79	129,57	170,78	211,58	252,05	221,79	158,70	120,73	95,80		
17	414,69	2,33	5,61	10,91	26,29	37,31	51,15	75,49	99,49	146,84	193,55	239,79	285,66	267,59	191,47	145,66	115,59		
19	462,96	2,60	6,27	12,19	29,38	41,70	57,17	84,37	111,20	164,12	216,33	268,00	319,27	316,17	226,23	172,10	136,58		
21	511,26	2,87	6,93	13,48	32,48	46,10	63,18	93,25	122,91	181,40	239,09	296,21	352,87	367,39	262,88	199,98	158,70		
23	599,61	3,15	7,59	14,76	35,57	50,48	69,20	102,13	134,62	124,07	261,86	324,42	386,48	421,10	301,32	229,22	181,90		
25	607,98	3,42	8,25	16,05	38,67	54,87	75,22	111,01	146,32	215,94	284,64	352,63	420,09	477,20	341,46	259,76	206,13		
Lubrication method		TYPE 1					TYPE 2					TYPE 3							

For multiple strand ratings – Refer multiple strand factor multiplier on page.  
For requirements at faster speeds, or sprocket sizes contact SKF

# Power Rating Tables (kW) – ANSI Chains

Table 10v

240H-1; (76.2 mm Pitch) Power ratings in kilowatt (ANSI standard)

No of teeth	Pitch circle Dia.	rpm of small (faster) sprocket $z_1$																	
		Z	mm	2	5	10	25	27	50	75	100	150	200	250	300	400	500	600	700
13	318,41	2,05	4,95	9,63	23,22	25,00	45,16	66,66	87,86	129,66	170,91	211,74	252,24	178,94	128,04	97,41	77,29		
15	366,50	2,37	5,71	11,12	26,79	28,84	52,11	76,91	101,37	149,61	197,21	244,32	291,04	221,79	158,70	120,73	95,80		
17	414,69	2,69	6,48	12,60	30,36	32,69	59,06	87,16	114,89	169,56	223,49	276,89	329,85	267,59	191,47	145,66	115,59		
19	462,96	3,01	7,24	14,08	33,93	36,53	66,01	97,42	128,41	189,51	249,79	309,46	368,66	316,17	226,23	172,10	136,58		
21	511,26	3,32	8,00	15,56	37,50	40,38	72,96	107,67	141,92	209,46	276,08	342,03	407,46	367,39	262,88	199,98	158,70		
23	599,61	3,63	8,76	17,05	41,07	44,22	79,90	117,93	155,44	229,41	302,38	374,61	446,26	421,10	301,32	229,22	181,90		
25	607,98	3,95	9,53	18,52	44,65	48,07	86,85	128,19	168,95	249,36	328,67	407,19	485,07	477,20	341,46	259,76	206,13		
Lubrication method		TYPE 1					TYPE 2					TYPE 3							

For multiple strand ratings – Refer multiple strand factor multiplier on page.  
For requirements at faster speeds, or sprocket sizes contact SKF

# Basic Selection procedure

The following are the basic procedures, based on the above guidelines and stated parameters, for the correct selection of a standard transmission chains

- Establish the power ( $P_M$ ) in kW for BS/DIN chains, or HP for ANSI series, to be transmitted. If the actual demand power is indeterminable, use the motor / prime-mover nameplate power.
- From Tables 2.1 and 2.2 select the relevant Service Factors for (a) the application ( $F_a$ ) and (b) the speed ( $F_n$ ) also considering all aspects of the additional factors detailed in the table footnote.
- Multiply the power by the Service Factor(s)... This will give the Design power ( $P_D$ )... the basis for selection

$$P_D = P_M \times F_a \times F_n \quad (\text{kW or HP})$$

- Confirm the ratio of the sprockets required to obtain the final (driven) speed, by dividing the faster speed by the low rpm.

$$\text{Sprocket ratio (i)} = \frac{\text{Faster speed } N_1}{\text{Faster speed } N_2} = \frac{Z_2}{Z_1}$$

- Select sprockets ( $Z_1$  and  $Z_2$ ) that will meet the ratio requirements.

As a general rule

- start with the smaller sprocket ( $Z_1$ ) being 19T.
- If the ratio is close to 1:1, try to use a larger number of teeth.
- For the benefit of even wear, use odd number of teeth on at least one of the sprockets.
- Avoid even numbers on both sprockets if possible.
- From either the BS / DIN (kW) Tables (→ **pages 15–18**) or the ANSI (kW) (→ **pages 19–26**) select a chain that has sufficient or greater capacity than the figure calculated in 6.3 above.  
NOTE: This selection is based on the faster sprocket speed ( $N_1$ )
- Check the pitch diameters of the sprockets selected, either from the **SKF PT General Catalogue PUB PT 11015 EN** (→ **pages 163–236**), or from the following formulae:

$$D_p = \text{Sin} \left( \frac{180}{Z} \right)^{-1}_{xp}$$

Where:

$D_p$  Pitch Diameter

$p$  chain pitch

$z$  No. of sprocket teeth

Use either mm, or inch  
for BOTH measurements  
(mm or inch)

- If the diameter is too large, consider a smaller pitch chain in multiple strands. For multiple strand chains, the power capacities shown in the Power Ratings tables MUST be re-adjusted by the factors shown in **Table 6, page 13** above.
- Calculate the actual chain length ( $L$ ) ensuring the shaft centres are between 30 and 80 pitches in length. Where possible the total chain length, including the complete number of pitches, including the connector id=s an even number, to avoid the use of an offset link (non-preferred).
- A check should also be made of the hub capacity to accept the required finished bore. Refer **SKF PT General Catalogue PUB PT 11015 EN** (→ **pages 163–236**).

## Special considerations

- If the chain is operating outside the  $-10\text{ }^{\circ}\text{C}$  to  $+150\text{ }^{\circ}\text{C}$  temperature range, the power rating values obtained in either (6.5) or (6.7) above, the power ratings obtained from the Power Ratings Tables, must be re-adjusted according to the factors shown in **table 3, page 11**.
- For materials other than the standard chains, (e.g. 300 and 400 class stainless steel) refer to SKF PTP for ratings).
- Refer to the INSTALLATION & MAINTENANCE instructions for guidelines on correct layouts, installation procedures, and lubrication types and recommendations

## Example

A chain drive is required for the final stage on a conveyor drive, from the out shaft of the gear reducer (57 rpm) to the conveyor head shaft (32 rpm). The electric motor power is 7.5 kW. The loading is light duty, with the shaft centre adjustable to suit. Shaft diameters are 65 mm and 55 mm respectively, with no space restrictions

**Step 1:** Establish the Service Factor for the application

From **table 1, page 10** the Service Factor for the duty given (uniform) is 1.0

**Step 2:** Calculate the Design Power (DP)

$$DP = 1.0 \times 7.5 = 7.5\text{ kW}$$

**Step 3:** Establish the ratio for the sprocket and select suitable teeth numbers

$$i = \frac{57}{32} = 1.78:1$$

**Step 4:** Make tentative selection of sprockets based on the ratio calculated in **step 3**

17T – 30T,

(most economical, but also 19T – 34T\* and 21T – 38T give an acceptable ratio (\*however the 34T is non standard size and should be avoided)

**Step 5:** Check the ratings table (BS/DIN) based on 17T @ 57rpm

If necessary consider multi strand chains, using the the Multiple Strand Factor (K2) to correct the chain capacity.

**5(i)** From the Power Ratings Tables for DIN/BS chain on **pages 15–18**, it can be seen that for a 17 Tooth sprocket at 57rpm, for 24B-1, **, by interpolation, has a capacity of**

$$kW = 9.61 + \left[ \frac{13.54 - 9.61}{25} \times 7 \right]$$

$$= 10.71\text{ kW}$$

**5(ii)** (NOTE: By using a Duplex chain 20B-2, a smaller drive is possible, with a capacity of 9.26 kW... (including the Multiple Strand Factor K2 of 1.7, as shown in **table 6, page 13**, still with sufficient capacity for the application).

**Step 6:** Check sprocket Diameters and bore capacities either by calculation ...

$$D_p = \text{Sin} \left( \frac{180}{Z} \right)^{-1} \times p$$

Where:

$D_p$  Pitch Diameter (mm or inch)

Z No. of Sprocket Teeth

P Chain pitch (mm or inch)

or referring to **SKF PT General Catalogue 11015 EN (II), page 173**

PHS 24B-1BH17	$D_p$	Ø207,35 mm
PHS 24B-1B30	$D_p$	Ø364,49 mm

Alternatively,

PHS 20-2BH17	$D_p$	Ø172,79 mm
PHS 20B-2B30	$D_p$	Ø303,75 mm

Note the smaller sprockets (17T) above are both offered with hardened teeth, as standard, indicated by the “H” in the designation

**Step 7**

Calculate the chain length.

The centres should be between 30 and 80 pitches for good life.

Use the formulae in (7) above.

$$L = \frac{Z_2 + Z_1}{2} + 2C + \frac{K}{C}$$

This calculates the length in pitches so the actual chain length (even in number preferably, to avoid the use of offset links) will be determined by the actual chain pitch chosen

**NOTE:** If the above example was operating at a temperature above 150 °C, the Power ratings would have to be re-rated, by a factor of 0,75, resulting in the 20B-2 no longer being an option.

Additionally, the 24B chain originally selected would need to be changed to a DUPLEX e.g. 24B-2. (The sprocket diameters will remain the same).

If we take the centre at (say) 40 pitches...

$$L = \frac{30 + 17}{2} + 80 + \frac{4.28}{40}$$

= 103.6 pitches

∴ Use 104 pitches including connector

(i) 104 pitches (3,962.4mm) PHC 24B-1...

(ii) 104 pitches (3,303,0mm) PHC 20B-2...

The option of the 20B-2 offers a more compact and cost effective solution in this instance.

1 1 off PHS 20B-2BH17

2 1 off PHS 20B-2B30

3 3,303 mm PHC 20B-2... including the connector

Sprockets are available with pilot bore, finished bore (upon request), or with the option of a Taper bush, in most sizes. The option of friction-locking assemblies (SKF FX bushings) is also available on request.

**NOTE:** This chain is usually available in either 10ft OR 5MTR boxes only. Each box contains one (1) connector.



## SKF chains

SKF chain range nomenclature has a defined prefix of PHC. All standardized chains we produce conform to conventional basic part number format – ISO, BS, or DIN.

## Roller chains

The Roller chains designation format is constant through the range, with the following example to indicate set up.

**SKF Designation prefix** PHC 80- 1 C X10FT

**Chain type** \_\_\_\_\_  
 ANSI – 25 -240  
 BS – 05B- 72B

**No of strands** \_\_\_\_\_  
 Simplex– single (-1), Duplex - double (-2)  
 Triplex – triple (-3)

**Supplementary** \_\_\_\_\_  
 Many different supplementary designations, examples  
 C- cottared type  
 SS – stainless steel  
 C/L – connector link

**Note**  
 See SKF product training for full supplementary notations

**Chain length** \_\_\_\_\_  
 Standard box – 10FT or 5MTR  
 Non standard example – 164LINKS

## SKF chains

SKF chain range nomenclature has a defined prefix of PHC. All standardized chains we produce conform to conventional basic part number format – ISO, BS, or DIN.

## Special chains – Leaf, Conveyor

The special and conveyor chains designation format is constant through the range, but there are very many combinations of materials, attachments and special considerations, the following is an example to indicate set up.

**SKF Designation prefix** PHC C2080H- L1A2 X10FT

**Chain type** \_\_\_\_\_  
 Leaf – BL, AL, FL, LL  
 Conveyor – C, M, FV, Z – variations based on hollow shafts, rollers and side plates heights

**Supplementary** \_\_\_\_\_  
 Many different supplementary designations, examples  
 C- cottared type  
 SS – stainless steel  
 C/L – connector link

**Note**  
 See SKF product training for full supplementary notations

**Chain length** \_\_\_\_\_  
 Standard box – 10FT or 5MTR  
 Non standard example – 164LINKS

# Chains (PHC Product Group)

SKF chains completely conform to international standards (ISO) and other advanced industrial standards (i.e. ANSI and DIN) as shown below:

- Short pitch transmission precision roller chains are manufactured according to ISO 606-1994, ASME B29.1M-1993 and DIN 8187/DIN 8188
- Double pitch precision roller chains for transmission and conveyors are manufactured according to ISO 1275-1995, ASME B29.3M-1994/AMSE B29.4M-1994 and DIN 8181-2000
- Short pitch transmission precision bush chains are manufactured according to ISO 1395-1997, ASME B29.12M-1997 and DIN 8154/DIN 8164
- Steel roller chains/attachments (types S and C) are manufactured according to ISO 487-1998, ASME B29.19M-1996 and DIN 8169-1997
- Conveyor chains/attachments are manufactured according to ISO 1977-2000, ASME B29.15M-1997 and DIN 8165/DIN 8166/DIN 8167
- Heavy duty cranked link transmission chains are manufactured according to ISO 3512, ASME B29.10M-1997 and DIN 8182  
Leaf chains are manufactured according to ISO 4347-1992, ASME B29.8M-1983 and DIN 8152
- Silent chains are manufactured according to ASME B29.2M-1982 and DIN 8190
- Oil field chains are manufactured according to API SPEC 7F-1993
- Hollow pin chains are manufactured according to ASME B29.27M-2001 and DIN 8168

Depending on the type and style, SKF conveyor chains comply with international standards such as DIN 8187, ISO 1977 and BS 4116 (Part IV).

Other cast and steel chains comply with the relevant industry accepted standards for performance and dimensions.

For the full range of SKF Conveyor Chains, please refer to SKF Conveyor Chain catalogue (**PUB PT/P2 10818 EN, Edition 2**).

For the full range of available sprockets please refer to SKF Power Transmission Products catalogue (**11015 EN, Edition 2, pages 161 to 236**).

This catalogue covers small pitch (SP) transmission drive chains, agricultural chains, SP attachment chain and a limited range of their attachments, where applicable.

For the full range of Long Pitch (LP) series conveyor, elevator and Engineered Steel chains, and attachments, please refer to **SKF PT catalogue PUB PT/P2 10818 EN**.



## Typical materials used in the chain construction

Side Plate	45Mn, 40Cr, 35CrMo, Premium carbon steel no. 45
Roller	Premium carbon steel no. 10, Premium carbon steel no. 45
Bush	20Mn Premium carbon steel no. 20
Pin	35CrMo, GCr15, 30CrMnTi, 40Cr, 20CrMnMo

# SKF American standard chains

American standard chains are covered by ISO 606, ANSI B29.1 and DIN 8188 standards.

The pitch sizes covered by this standard are 1/4 to 3 inch. American standard chains have a smaller pin diameter than the European standard equivalent. Wear resistance is therefore reduced when compared with the European standard chains. One exception is the 5/8 inch pitch, as in this case the pin and bushing diameters are larger than the European equivalent.

American standard chains are normally referred to under the ANSI standard numbering system, for example a 1/2 inch pitch duplex (double strand) chain would be ANSI 40-2.

The ANSI numbering system works as follows: The first number is the pitch size in 1/8 inch, i.e.  $4/8 = 1/2$  inch pitch. The second number refers to the chain being a roller chain, i.e. 0 = roller chain. A number 5 replacing the 0 would indicate a bushing chain and number 1 indicates a narrower series. The suffix, as with European standard chain, refers to the number of strands in the chain, that is in this case 2 = duplex (double strand) chain.

Table 1

## American Standard chains

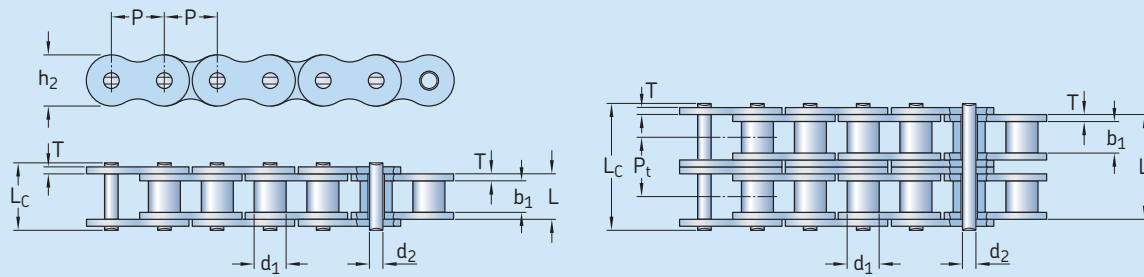

ANSI Chain number	BS/ISO Chain number	Dimensions										Ultimate tensile strength	Average tensile strength	Weight per meter	Designation
		Pitch	Roller diameter	Width between inner plates	Pin diameter	Pin length		Pin length cottored	Inner plate height	Plate thickness	Transverse pitch				
		P	d <sub>1</sub> max	b <sub>1</sub> max	d <sub>2</sub> max	L max	L <sub>c</sub> max	L <sub>c</sub> max	h <sub>2</sub> max	T max	P <sub>t</sub>	Q min	Q <sub>0</sub>	q	
		mm										kN		kg/m	
15-1*	03C*	4,7625	2,48	2,38	1,62	6,1	6,9	-	4,3	0,6	-	1,8	2	0,08	PHC 15-1...
25-1*	04C-1*	6,350	3,30	3,18	2,31	7,90	8,40	-	6,00	0,80	-	3,5	4,6	0,15	PHC 25-1...
35-1*	06C-1*	9,525	5,08	4,77	3,58	12,40	13,17	-	9,00	1,30	-	7,9	10,8	0,33	PHC 35-1...
41-1	085-1	12,700	7,77	6,25	3,58	13,75	15,00	-	9,91	1,30	-	6,7	12,6	0,41	PHC 41-1...
40-1	08A-1	12,700	7,95	7,85	3,96	16,60	17,80	-	12,00	1,50	-	14,1	17,5	0,62	PHC 40-1...
50-1	10A-1	15,875	10,16	9,40	5,08	20,70	22,20	23,30	15,09	2,03	-	22,2	29,4	1,02	PHC 50-1...
60-1	12A-1	19,050	11,91	12,57	5,94	25,90	27,70	28,30	18,00	2,42	-	31,8	41,5	1,50	PHC 60-1...
80-1	16A-1	25,400	15,88	15,75	7,92	32,70	35,00	36,50	24,00	3,25	-	56,7	69,4	2,60	PHC 80-1...
100-1	20A-1	31,750	19,05	18,90	9,53	40,40	44,70	44,70	30,00	4,00	-	88,5	109,2	3,91	PHC 100-1...
120-1	24A-1	38,100	22,23	25,22	11,10	50,30	54,30	54,30	35,70	4,80	-	127,0	156,3	5,62	PHC 120-1...
140-1	28A-1	44,450	25,40	25,22	12,70	54,40	59,00	59,00	41,00	5,60	-	172,4	212,0	7,50	PHC 140-1...
160-1	32A-1	50,800	28,58	31,55	14,27	64,80	69,60	69,60	47,80	6,40	-	226,8	278,9	10,10	PHC 160-1...
180-1	36A-1	57,150	35,71	35,48	17,46	72,80	78,60	78,60	53,60	7,20	-	280,2	341,8	13,45	PHC 180-1...
200-1	40A-1	63,500	39,68	37,85	19,85	80,30	87,20	87,20	60,00	8,00	-	353,8	431,6	16,15	PHC 200-1...
240-1	48A-1	76,200	47,63	47,35	23,81	95,50	103,00	103,00	72,39	9,50	-	510,3	622,5	23,20	PHC 240-1...
25-2*	04C-2*	6,350	3,30	3,18	2,31	14,5	15,0	-	6,00	0,80	6,40	7,0	8,6	0,28	PHC 25-2...
35-2*	06C-2*	9,525	5,08	4,77	3,58	22,5	23,3	-	9,00	1,30	10,13	15,8	19,7	0,63	PHC 35-2...
41-2	085-2	12,700	7,77	6,25	3,58	25,7	26,9	-	9,91	1,30	11,95	13,3	16,9	0,81	PHC 41-2...
40-2	08A-2	12,700	7,95	7,85	3,96	31,0	32,2	-	12,00	1,50	14,38	28,2	35,9	1,12	PHC 40-2...
50-2	10A-2	15,875	10,16	9,40	5,08	38,9	40,4	41,2	15,09	2,03	18,11	44,4	58,1	2,00	PHC 50-2...
60-2	12A-2	19,050	11,91	12,57	5,94	48,8	50,5	51,1	18,00	2,42	22,78	63,6	82,1	2,92	PHC 60-2...
80-2	16A-2	25,400	15,88	15,75	7,92	62,7	64,3	65,8	24,00	3,25	29,29	113,4	141,8	5,15	PHC 80-2...
100-2	20A-2	31,750	19,05	18,90	9,53	76,4	80,5	80,5	30,00	4,00	35,76	177,0	219,4	7,80	PHC 100-2...
120-2	24A-2	38,100	22,23	25,22	11,10	95,8	99,7	99,7	35,70	4,80	45,44	254,0	314,9	11,70	PHC 120-2...
140-2	28A-2	44,450	25,40	25,22	12,70	103,3	107,9	107,9	41,00	5,60	48,87	344,8	427,5	15,14	PHC 140-2...
160-2	32A-2	50,800	28,58	31,55	14,27	123,3	128,1	128,1	47,80	6,40	58,55	453,6	562,4	20,14	PHC 160-2...
180-2	36A-2	57,150	35,71	35,48	17,46	138,6	144,4	144,4	53,60	7,20	65,84	560,5	695,0	29,22	PHC 180-2...
200-2	40A-2	63,500	39,68	37,85	19,85	151,9	158,8	158,8	60,00	8,00	71,55	707,6	877,4	32,24	PHC 200-2...
240-2	48A-2	76,200	47,63	47,35	23,81	183,4	190,8	190,8	72,39	9,50	87,83	1020,6	1255,3	45,23	PHC 240-2...
25-3*	04C-3*	6,350	3,30	3,18	2,31	21,0	21,5	-	6,00	0,80	6,40	10,5	12,6	0,44	PHC 25-3...
35-3*	06C-3*	9,525	5,08	4,77	3,58	32,7	33,5	-	9,00	1,30	10,13	23,7	28,6	1,05	PHC 35-3...
40-3	08A-3	12,700	7,95	7,85	3,96	45,4	46,6	-	12,00	1,50	14,38	42,3	50,0	1,90	PHC 40-3...
50-3	10A-3	15,875	10,16	9,40	5,08	57,0	58,5	59,3	15,09	2,03	18,11	66,6	77,8	3,09	PHC 50-3...
60-3	12A-3	19,050	11,91	12,57	5,94	71,5	73,3	73,9	18,00	2,42	22,78	95,4	111,1	4,54	PHC 60-3...
80-3	16A-3	25,400	15,88	15,75	7,92	91,7	93,6	95,1	24,00	3,25	29,29	170,1	198,4	7,89	PHC 80-3...
100-3	20A-3	31,750	19,05	18,90	9,53	112,2	116,3	116,3	30,00	4,00	35,76	265,5	309,6	11,77	PHC 100-3...
120-3	24A-3	38,100	22,23	25,22	11,10	141,4	145,2	145,2	35,70	4,80	45,44	381,0	437,2	17,53	PHC 120-3...
140-3	28A-3	44,450	25,40	25,22	12,70	152,2	156,8	156,8	41,00	5,60	48,87	517,2	593,3	22,20	PHC 140-3...
160-3	32A-3	50,800	28,58	31,55	14,27	181,8	186,6	186,6	47,80	6,40	58,55	680,4	780,6	30,02	PHC 160-3...
180-3	36A-3	57,150	35,71	35,48	17,46	204,4	210,2	210,2	53,60	7,20	65,84	840,7	983,6	38,22	PHC 180-3...
200-3	40A-3	63,500	39,68	37,85	19,85	223,5	230,4	230,4	60,00	8,00	71,55	1061,4	1217,8	49,03	PHC 200-3...
240-3	48A-3	76,200	47,63	47,35	23,81	271,3	278,6	278,6	72,39	9,50	87,83	1530,9	1756,5	71,60	PHC 240-3...

\* Bushing chain: d<sub>1</sub> indicates external diameter of bushing.

Standard lengths are 10 ft. and 5 m. To complete designation, add chain length. For example, a 10 ft. box of 140-1 is PHC 140-1X10FT.

For links, add "C/L" for "connecting" and "O/L" for "offset" to the designation.

For cottored, add a "C" after the number of strands. For example, 140-1 with a cottored pin is designated PHC 140-1C.

# SKF BS European standard chains

Chains manufactured to the BS standards are covered by ISO606, BS228 and DIN 8187.

The pitch sizes covered by this standard are 6 mm (0,236 inch) to 114,3 mm (4,500 inch). They are characterised by a larger pin diameter than the ANSI chain. This results in better wear resistance due to a larger load bearing area.

The BS chain numbering system works as follows, i.e. 1/2 inch pitch duplex (double strand) chain would be 08B-2. The first two digits are the pitch size in 1/16 of an inch, therefore 08 = 8/16 or 1/2 inch. The letter B indicates the European standard.

The suffix 2 indicates the number of strands in the chain, in this case a duplex (double strand) chain.

BS chains resemble ASME/ANSI standard chains and are identical in pitch, however, there are other significant dimensional differences which distinguish them from ASME/ANSI standard chains.

C



# SKF Xtra Corrosion Resistant Chains

## Stainless steel chains

Stainless steel chains have superior corrosion resistance for the most demanding applications. SKF offers a variety of such chains for applications where a high level of cleanliness is required or harsh chemicals are used. SKF stainless steel chains are made from SS304 grade steel for high corrosion resistance and are available in BS and ANSI standards. SS316 and other stainless steel grades are available for higher temperature applications. The SS316 stainless steel is somewhat more resistant to the effects of magnetic permeability, temperature extremes and harsher chemicals.

### Application

These chains are suitable for food processing, pharmaceutical, high/low temp (-20 to 400 °C) and corrosive environments.

Stainless steel chains can be manufactured to withstand temperatures up to 1 000 °C with the addition of special lubricant.



*Stainless steel chains used in a cheese processing plant*



*Anti corrosive chains are either made of stainless steel or are covered with a special coating*

Table 1

## SKF Xtra Corrosion Resistant Chains

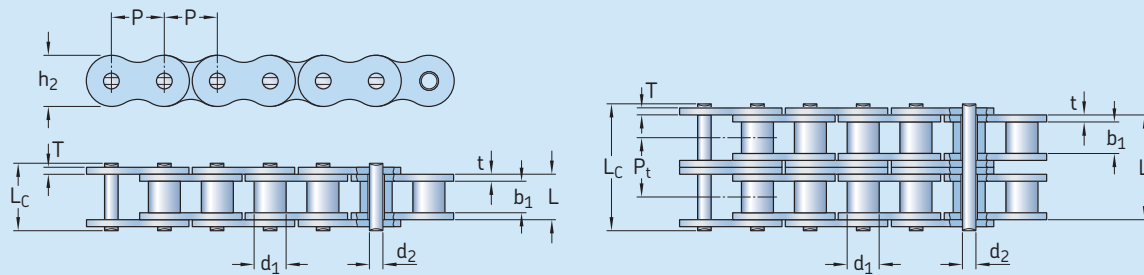

Chain number	Dimensions					Inner plate height	Plate thickness			Ultimate tensile strength	Weight per meter	Designation	
	Pitch	Roller diameter	Width between inner plates	Pin diameter	Pin length		t max	T max	h <sub>2</sub> max				
	P	d <sub>1</sub> max	b <sub>1</sub> min	d <sub>2</sub> max	L max	L <sub>c</sub> max	h <sub>2</sub> max	t max	T max	Q min	q		
	mm										kN	kg/m	-
<b>25-1SS1</b>	6,350	3,30	3,18	2,31	7,90	8,40	6,00	0,80	0,80	2,5	0,15	PHC 25-1SS...	
<b>35-1SS1</b>	9,525	5,08	4,77	3,58	12,40	13,17	9,00	1,30	1,30	5,5	0,33	PHC 35-1SS...	
<b>40-1SS</b>	12,700	7,95	7,85	3,96	16,60	17,80	12,00	1,50	1,50	9,6	0,63	PHC 40-1SS...	
<b>41-1SS</b>	12,700	7,77	6,25	3,58	13,75	15,00	9,91	1,30	1,30	6,0	0,46	PHC 41-1SS...	
<b>50-1SS</b>	15,875	10,16	9,40	5,08	20,70	22,20	15,09	2,03	2,03	15,2	1,03	PHC 50-1SS...	
<b>60-1SS</b>	19,050	11,91	12,57	5,94	25,90	27,70	18,00	2,42	2,42	21,7	1,51	PHC 60-1SS...	
<b>80-1SS</b>	25,400	15,88	15,75	7,92	32,70	35,00	24,00	3,25	3,25	38,9	2,62	PHC 80-1SS...	
<b>100-1SS</b>	31,750	19,05	18,90	9,53	40,40	44,70	30,00	4,00	4,00	60,0	3,94	PHC 100-1SS...	
<b>120-1SS</b>	38,100	22,23	25,22	11,10	50,30	54,30	35,70	4,80	4,80	72,5	5,72	PHC 120-1SS...	
<b>140-1SS</b>	44,450	25,40	25,22	12,70	54,40	59,00	41,00	5,60	5,60	94,0	7,70	PHC 140-1SS...	
<b>04B-1SS</b>	6,000	4,00	2,80	1,85	6,80	7,80	5,00	0,60	0,60	2,0	0,11	PHC 04B-1SS...	
<b>05B-1SS</b>	8,000	5,00	3,00	2,31	8,20	8,90	7,10	0,80	0,80	3,5	0,20	PHC 05B-1SS...	
<b>06B-1SS<sup>2</sup></b>	9,525	6,35	5,72	3,28	13,15	14,10	8,20	1,30	1,30	6,2	0,41	PHC 06B-1SS...	
<b>08B-1SS</b>	12,700	8,51	7,75	4,45	16,70	18,20	11,80	1,60	1,60	12,0	0,70	PHC 08B-1SS...	
<b>10B-1SS</b>	15,875	10,16	9,65	5,08	19,50	20,90	14,70	1,70	1,70	14,5	0,94	PHC 10B-1SS...	
<b>12B-1SS</b>	19,050	12,07	11,68	5,72	22,50	24,20	16,00	1,85	1,85	18,5	1,16	PHC 12B-1SS...	
<b>16B-1SS</b>	25,400	15,88	17,02	8,28	36,10	37,40	21,00	4,15	3,10	40,0	2,73	PHC 16B-1SS...	
<b>20B-1SS</b>	31,750	19,05	19,56	10,19	41,30	45,00	26,40	4,50	3,50	59,0	3,73	PHC 20B-1SS...	
<b>24B-1SS</b>	38,100	25,40	25,40	14,63	53,40	57,80	33,20	6,00	4,80	104,0	7,20	PHC 24B-1SS...	
<b>32B-1SS</b>	50,800	29,21	30,99	17,81	66,00	71,00	42,00	7,00	6,00	150,0	10,22	PHC 32B-1SS...	

<sup>1</sup> Bushing chain: d<sub>1</sub> indicates external diameter of bushing.

<sup>2</sup> Straight side plates.

Standard lengths are 10 ft. and 5 m. To complete designation, add chain length. For example, a 5 m box of 80-1SS is PHC 80-1SSX5MTR. For links, add "C/L" for "connecting" and "O/L" for "offset" to the designation.



## Nickel-plated

Nickel-plated roller chains combine the strength of standard roller chains with the corrosion resistant properties that come from the nickel-plating. Nickel-plating of all components prior to assembly promotes uniform coverage during the plating process.

### Application

Nickel-plated chains are not suitable in applications that may involve contact with food.

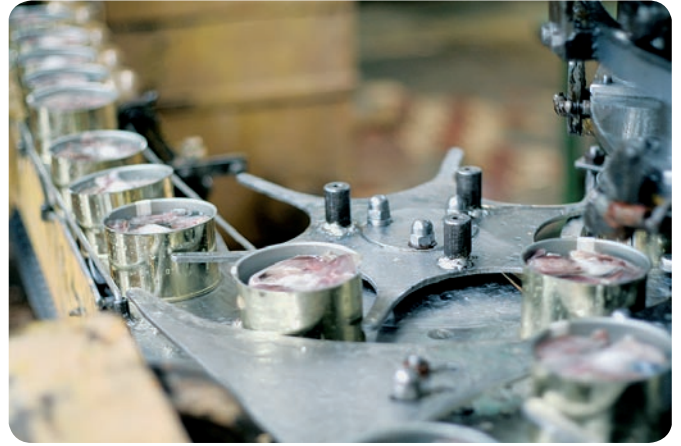

*Nickel-plated chains used in a canning plant*

## Zinc-plated

Zinc-plated roller chains provide a very good adherence of the plating to the base metal and combines the strength of standard roller chains with the corrosion resistance that comes from zinc-plating. Zinc-plating of all components prior to assembly promotes uniform coverage during the plating process. Zinc-plating is more cost-effective than nickel-plating.

### Application

Zinc-plated chains are typically used in outdoor applications and where there is exposure to sea/salt water environments.



*Zinc-plated chains used in automatic car washes*

## Dacrotized chains

Dacrotizing is a process of metal coating. The compositions are proprietary water based coating dispersions containing metal oxides, metallic zinc and aluminium flakes. The zinc and aluminium platelets align themselves in multiple layers forming a metallic silver gray coating. Overlapping zinc and aluminium flakes provide an excellent protective barrier and the zinc corrodes to protect the steel. Due to the concentration of aluminum within the coating, the result is good bi-metallic corrosion resistance. Damaged areas in the coating will fill with zinc oxides and carbonates, thus repairing itself. The dacrotizing process can be applied to numerous types of chains. For additional information, contact SKF.

### Application

These chains are suitable for extremely corrosive environments without loss of strength.



*Dacrotized chains used in a fish processing plant*

Table 2

#### Plated chains are available as:

<b>Zinc-plated</b>	A cost-effective way to increase corrosion resistance
<b>Nickel-plated</b>	Improved wear resistance Recommended for outdoor conditions, such as exposure to rain
<b>Dacrotized</b>	Suitable for corrosive conditions

Please refer to pages **85** to **87** for further details on corrosion resistant chains.

## Dacrotised and plated chains

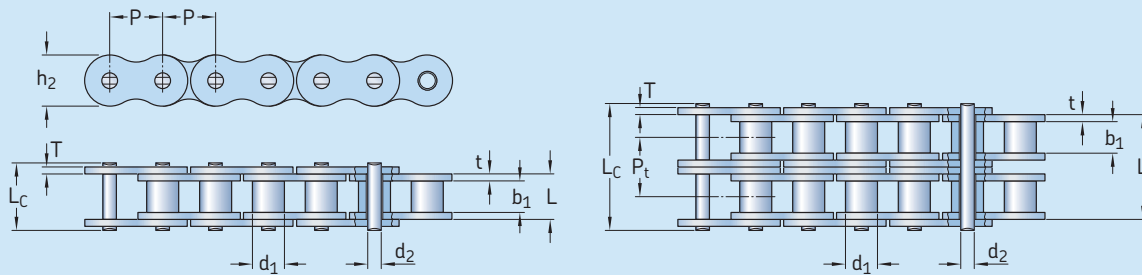

Chain number	Dimensions					Pin length	Inner plate height	Plate thickness		Ultimate tensile strength	Weight per meter	Designation	
	Pitch	Roller diameter	Width between inner plates	Pin diameter	Pin length			t max	T max				
	P	d <sub>1</sub> max	b <sub>1</sub> min	d <sub>2</sub> max	L max	L <sub>c</sub> max	h <sub>2</sub> max	t max	T max	Q min	q		
	mm										kN	kg/m	-
25-1 <sup>1</sup>	6,350	3,30	3,18	2,31	7,90	8,40	6,00	0,80	0,80	3,5	0,15	PHC 25-1...	
35-1 <sup>1</sup>	9,525	5,08	4,77	3,58	12,40	13,17	9,00	1,30	1,30	7,9	0,33	PHC 35-1...	
41-1	12,700	7,77	6,25	3,58	13,75	15,00	9,91	1,30	1,30	6,7	0,41	PHC 41-1...	
40-1	12,700	7,95	7,85	3,96	16,60	17,80	12,00	1,50	1,50	14,1	0,62	PHC 40-1...	
50-1	15,875	10,16	9,40	5,08	20,70	22,20	15,09	2,03	2,03	22,2	1,02	PHC 50-1...	
60-1	19,050	11,91	12,57	5,94	25,90	27,70	18,00	2,42	2,42	31,8	1,50	PHC 60-1...	
80-1	25,400	15,88	15,75	7,92	32,70	35,00	24,00	3,25	3,25	56,7	2,60	PHC 80-1...	
100-1	31,750	19,05	18,90	9,53	40,40	44,70	30,00	4,00	4,00	88,5	3,91	PHC 100-1...	
120-1	38,100	22,23	25,22	11,10	50,30	54,30	35,70	4,80	4,80	127,0	5,62	PHC 120-1...	
140-1	44,450	25,40	25,22	12,70	54,40	59,00	41,00	5,60	5,60	172,4	7,50	PHC 140-1...	
160-1	50,800	28,58	31,55	14,27	64,80	69,60	47,80	6,40	6,40	226,8	10,10	PHC 160-1...	
04B-1	6,000	4,00	2,80	1,85	6,80	7,80	5,00	0,60	0,60	3,0	0,11	PHC 04B-1...	
05B-1	8,000	5,00	3,00	2,31	8,20	8,90	7,10	0,80	0,80	5,0	0,20	PHC 05B-1...	
06B-1 <sup>2</sup>	9,525	6,35	5,72	3,28	13,15	14,10	8,20	1,30	1,30	9,0	0,41	PHC 06B-1...	
08B-1	12,700	8,51	7,75	4,45	16,70	18,20	11,80	1,60	1,60	18,0	0,69	PHC 08B-1...	
10B-1	15,875	10,16	9,65	5,08	19,50	20,90	14,70	1,70	1,70	22,4	0,93	PHC 10B-1...	
12B-1	19,050	12,07	11,68	5,72	22,50	24,20	16,00	1,85	1,85	60,0	1,15	PHC 12B-1...	
16B-1	25,400	15,88	17,02	8,28	36,10	37,40	21,00	4,15	3,10	95,0	2,71	PHC 16B-1...	
20B-1	31,750	19,05	19,56	10,19	41,30	45,00	26,40	4,50	3,50	95,0	3,70	PHC 20B-1...	
24B-1	38,100	25,40	25,40	14,63	53,40	57,80	33,20	6,00	4,80	160,0	7,10	PHC 24B-1...	
28B-1	44,450	27,94	30,99	15,90	65,10	69,50	36,70	7,50	6,00	200,0	8,50	PHC 28B-1...	
32B-1	50,800	29,21	30,99	17,81	66,00	71,00	42,00	7,00	6,00	250,0	10,25	PHC 32B-1...	

<sup>1</sup> Bushing chain: d<sub>1</sub> indicates external diameter of bushings.

<sup>2</sup> Straight side plates.

Note: Duplex and double pitch plated chains are available in all sizes.

When ordering plated chains, add a suffix to the Chain number: according to material selection;

For example: PHC 50-1DR... 50-1 ANSI Simplex **Dacrotized** chain  
 PHC 60-2NP... 60-2 ANSI Duplex **Nickel-plated** chain  
 PHC 10B-1ZP... 10B-1 BS/ISO Simplex **Zinc-plated** chain

Standard lengths are 10 ft. and 5 m. To complete designation, add chain length. For example, a 10 ft. box of 12B-1DR is PHC 12B-1DRX10FT.

For links, add "C/L" for "connecting" and "O/L" for "offset" to the designation.

# Attachments

Attachments are normally used to allow a chain to perform a conveying function. The holes in the attachments are used to join two strands of chain together to allow them to run as a pair. Hooks can also be inserted through the holes to allow the chain to carry objects. These attachments can also assist control systems by activating magnetic pickup or proximity switches.

Table 4

## Attachments A-1, K-1

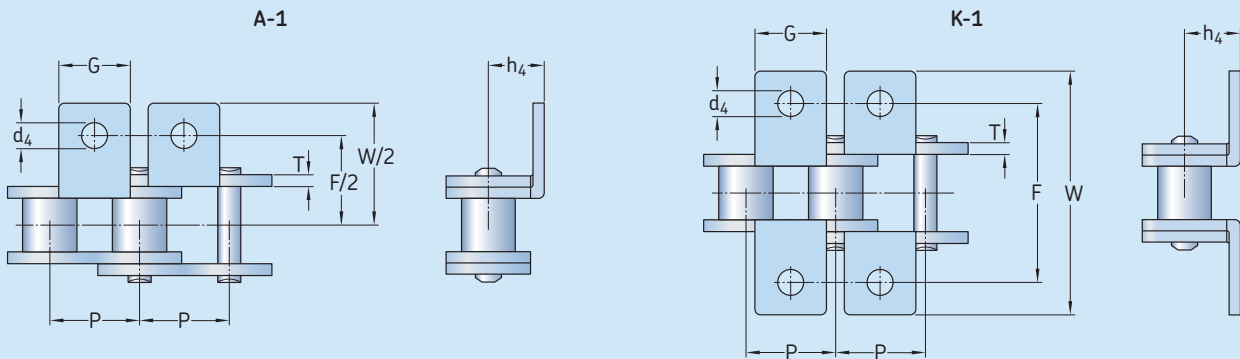

ANSI Chain number	BS/ISO Chain number	Dimensions		F	W	T	h <sub>4</sub>	d <sub>4</sub>	Designation
		P	G						
-	-	mm		-	-	-	-	-	-
35-1	06C-1	9,53	7,90	19,00	28,60	1,30	6,35	3,40	PHC 35-1...
40-1	08A-1	12,70	9,50	25,40	35,20	1,50	7,90	3,40	PHC 40-1...
41-1	085-1	12,70	9,50	24,00	33,40	1,30	6,90	3,60	PHC 41-1...
50-1	10A-1	15,88	12,70	31,75	46,20	2,03	10,30	5,50	PHC 50-1...
60-1	12A-1	19,05	15,90	38,10	55,60	2,42	11,90	5,50	PHC 60-1...
80-1	16A-1	25,40	19,10	50,80	64,80	3,25	15,90	6,80	PHC 80-1...
100-1	20A-1	31,75	25,40	63,50	87,30	4,00	19,80	9,20	PHC 100-1...
120-1	24A-1	38,10	28,60	76,20	108,50	4,80	23,00	9,80	PHC 120-1...
140-1	28A-1	44,45	34,90	88,90	123,00	5,60	28,60	11,40	PHC 140-1...
160-1	32A-1	50,80	38,10	101,60	142,80	6,40	31,75	13,10	PHC 160-1...
200-1	40A-1	63,50	50,80	127,00	179,00	8,00	42,88	16,30	PHC 200-1...
-	06B-1*	9,53	8,00	19,04	27,00	1,30	6,50	3,50	PHC 06B-1...
-	08B-1	12,70	9,50	25,40	36,40	1,60	8,90	4,50	PHC 08B-1...
-	10B-1	15,88	14,30	31,75	44,60	1,70	10,31	5,30	PHC 10B-1...
-	12B-1	19,05	16,00	38,10	52,40	1,85	13,46	6,40	PHC 12B-1...
-	16B-1	25,40	19,10	50,80	72,60	3,10	15,88	6,40	PHC 16B-1...
-	20B-1	31,75	35,00	63,50	100,50	3,50	19,80	9,00	PHC 20B-1...
-	24B-1	38,10	30,00	76,20	108,40	4,80	26,67	10,50	PHC 24B-1...
-	28B-1	44,45	35,00	88,90	123,00	6,00	28,58	13,10	PHC 28B-1...
-	32B-1	50,80	38,10	101,60	142,80	6,00	31,75	13,10	PHC 32B-1...

\* Straight side plates.  
 To complete designation, add attachment spacing and type followed by chain length.  
 For example: PHC 40-1-L2A1X10FT (ANSI 40-1 with A-1 attachment on every second link, 10 ft. length).  
 Note: Also available in stainless steel. When ordering, add SS after the chain number.  
 For example: PHC 40-1SS-L1A1X10FT.

Table 5

## Attachments SA-1/M1, SK-1/M1

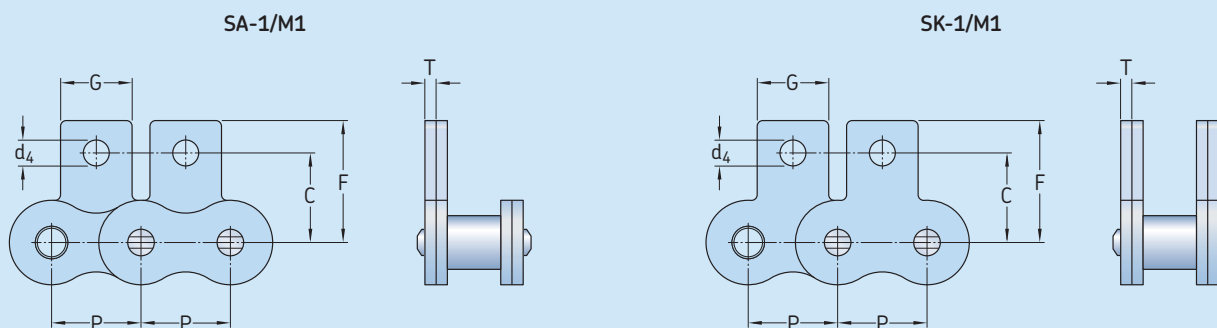

ANSI Chain number	BS/ISO Chain number	Dimensions P	G	C	F	T	d <sub>4</sub>	Designation
–	–	mm						–
35-1	06C-1	9,53	7,90	9,50	14,55	1,30	3,40	PHC 35-1...
40-1	08A-1	12,70	9,50	12,70	19,05	1,50	3,40	PHC 40-1...
41-1	085-1	12,70	9,50	11,85	16,55	1,30	3,60	PHC 41-1...
50-1	10A-1	15,88	12,70	15,90	25,25	2,03	5,50	PHC 50-1...
60-1	12A-1	19,05	15,90	18,30	29,33	2,42	5,50	PHC 60-1...
80-1	16A-1	25,40	19,10	24,60	34,70	3,25	6,80	PHC 80-1...
100-1	20A-1	31,75	25,40	31,80	43,30	4,00	9,20	PHC 100-1...
120-1	24A-1	38,10	28,60	36,50	51,60	4,80	9,80	PHC 120-1...
140-1	28A-1	44,45	34,90	44,50	62,00	5,60	11,40	PHC 140-1...
160-1	32A-1	50,80	38,10	50,80	69,85	6,40	13,10	PHC 160-1...
200-1	40A-1	63,50	50,80	63,50	88,90	8,00	16,30	PHC 200-1...
–	06B-1*	9,53	8,00	9,52	13,50	1,30	3,50	PHC 06B-1...
–	08B-1	12,70	9,50	13,35	18,90	1,60	4,30	PHC 08B-1...
–	10B-1	15,88	14,30	16,50	22,95	1,70	5,30	PHC 10B-1...
–	12B-1	19,05	16,00	21,45	28,60	1,85	6,40	PHC 12B-1...
–	16B-1	25,40	19,10	23,15	34,00	3,10	6,40	PHC 16B-1...
–	20B-1	31,75	35,00	30,50	45,70	3,50	9,00	PHC 20B-1...

\* Straight side plates.

To complete designation, add attachment spacing and type followed by chain length.  
For example: PHC 80-1-L1SK1X10FT (ANSI 80-1 with SK-1 attachment on every link, 10 ft. length).

Note: Also available in stainless steel. When ordering add SS after the chain number.

For example: PHC 80-1SS-L1SK1X10FT.

Table 6

## Attachments WA-1, WA-2, WK-1, WK-2

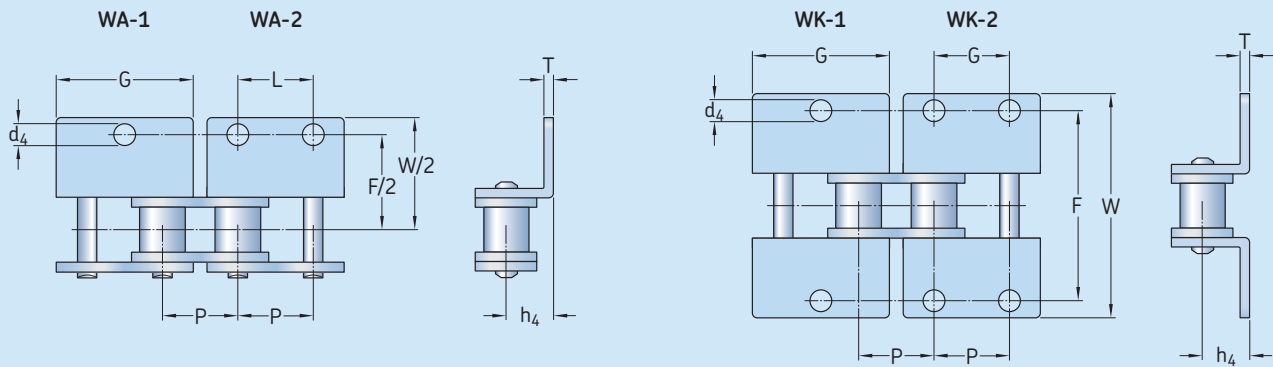

ANSI Chain number	BS/ISO Chain number	Dimensions		L	F	W	T	h <sub>4</sub>	d <sub>4</sub>	Designation
		P	G							
–	–	mm		–	–	–	–	–	–	–
35-1	06C-1	9,53	17,32	9,53	19,00	28,60	1,30	6,35	2,80	PHC 35-1...
40-1	08A-1	12,70	23,00	12,70	25,40	35,60	1,50	7,90	3,40	PHC 40-1...
41-1	085-1	12,70	22,30	12,70	24,00	35,00	1,30	7,20	4,85	PHC 41-1...
50-1	10A-1	15,88	28,80	15,88	31,75	46,80	2,03	10,30	5,50	PHC 50-1...
60-1	12A-1	19,05	34,65	19,05	38,10	56,40	2,42	11,90	5,50	PHC 60-1...
80-1	16A-1	25,40	45,90	25,40	50,80	73,20	3,25	15,90	6,80	PHC 80-1...
100-1	20A-1	31,75	57,65	31,75	63,50	89,80	4,00	19,80	9,20	PHC 100-1...
120-1	24A-1	38,10	69,30	38,10	76,20	108,80	4,80	23,00	9,80	PHC 120-1...
140-1	28A-1	44,45	80,45	44,45	88,90	123,00	5,60	28,60	11,40	PHC 140-1...
160-1	32A-1	50,80	92,00	50,80	101,60	142,80	6,40	31,75	13,10	PHC 160-1...
200-1	40A-1	63,50	115,50	63,50	127,00	179,00	8,00	42,88	16,30	PHC 200-1...
–	08B-1	12,70	24,00	12,70	25,40	36,40	1,60	8,90	4,30	PHC 08B-1...
–	10B-1	15,88	29,58	15,88	31,80	44,60	1,70	10,31	5,30	PHC 10B-1...
–	12B-1	19,05	34,05	19,05	38,10	52,00	1,85	13,46	6,40	PHC 12B-1...
–	16B-1	25,40	46,40	25,40	50,80	72,60	3,10	15,88	6,40	PHC 16B-1...
–	20B-1	31,75	58,10	31,75	63,00	100,50	3,50	19,80	9,00	PHC 20B-1...
–	24B-1	38,10	71,30	38,10	76,20	108,40	4,80	26,67	10,50	PHC 24B-1...
–	28B-1	44,45	81,10	44,45	88,90	123,00	6,00	28,58	13,10	PHC 28B-1...
–	32B-1	50,80	92,80	50,80	101,60	142,80	6,00	31,75	13,10	PHC 32B-1...

To complete designation, add attachment spacing and type followed by chain length.  
 For example: PHC 80-1-L2WA2X10FT (ANSI 80-1 with WA-2 attachment on every second link, 10 ft. (length)).  
 Note: Also available in stainless steel. When ordering add SS after the chain number.  
 For example: PHC 80-1SS-L2WA2X10FT.

Table 7

## Attachments WSA-1, WSA-2, WSK-1, WSK-2

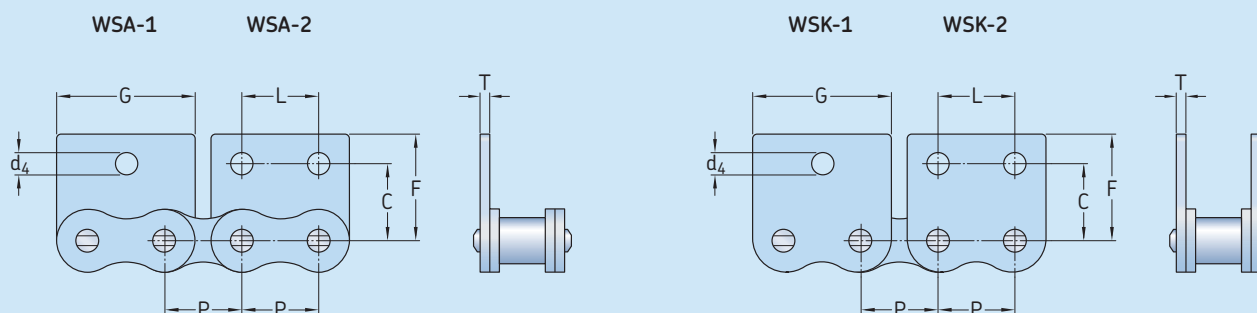

ANSI Chain number	BS/ISO Chain number	Dimensions		L	C	F	T	d <sub>4</sub>	Designation
		P	G						
-	-	mm		-	-	-	-	-	-
35-1	06C-1	9,53	17,32	9,53	9,50	14,55	1,30	2,80	PHC 35-1...
40-1	08A-1	12,70	23,00	12,70	12,70	17,40	1,50	3,40	PHC 40-1...
41-1	085-1	12,70	21,20	12,70	11,85	16,55	1,30	3,60	PHC 41-1...
50-1	10A-1	15,88	28,80	15,88	15,90	23,05	2,03	5,50	PHC 50-1...
60-1	12A-1	19,05	34,65	19,05	18,30	26,86	2,42	5,50	PHC 60-1...
80-1	16A-1	25,40	45,90	25,40	24,60	35,45	3,25	6,80	PHC 80-1...
100-1	20A-1	31,75	57,65	31,75	31,80	44,00	4,00	9,20	PHC 100-1...
120-1	24A-1	38,10	69,30	38,10	36,50	51,60	4,80	9,80	PHC 120-1...
140-1	28A-1	44,45	80,45	44,45	44,50	62,00	5,60	11,40	PHC 140-1...
160-1	32A-1	50,80	92,00	50,80	50,80	69,85	6,40	13,10	PHC 160-1...
200-1	40A-1	63,50	115,50	63,50	63,50	88,90	8,00	16,30	PHC 200-1...
-	08B-1	12,70	23,30	12,70	13,35	18,90	1,60	4,30	PHC 08B-1...
-	10B-1	15,88	29,58	15,88	16,50	22,95	1,70	5,30	PHC 10B-1...
-	12B-1	19,05	34,05	19,05	21,45	28,60	1,85	6,40	PHC 12B-1...
-	16B-1	25,40	46,40	25,40	23,15	34,00	3,10	6,40	PHC 16B-1...
-	20B-1	31,75	58,10	31,75	30,50	45,70	3,50	9,00	PHC 20B-1...

To complete designation, add attachment spacing and type followed by chain length.  
 For example: PHC 80-1-L4WSA1X10FT (ANSI 80-1 with WSA-1 attachment on every fourth link, 10 ft. (length)).  
 Note: Also available in stainless steel. When ordering add SS after the chain number.  
 For example: PHC 80-1SS L4WSA1X10FT.

# SKF Xtra Strength Chains

Using tensile strength as the measure of a quality chain does not always provide a complete picture. While tensile strength is important to use in calculating the maximum chain pull, useful in lifting calculations, this does not always represent the fatigue life and performance of the chain.

The pattern of the work load is particularly complex in heavy drive environments where significant shock loads are present. This can lead to rapid elongation and chain failure.

Therefore the SKF Xtra Strength Chain design includes, optimized hardness of the material, precision fit of the components as well as an overall size increase of the parts. This will in turn provide a much longer service life for the chain in demanding drive conditions.



*SKF Xtra Strength Chains used in logging applications*

**Tensile strength comparison**

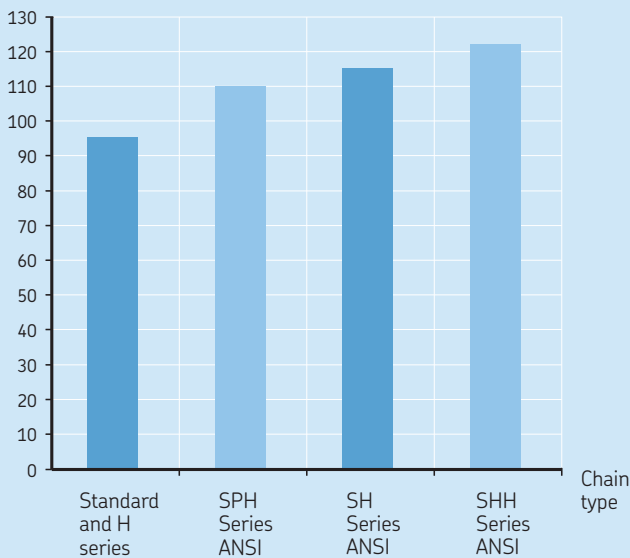

**Allowable load comparison**

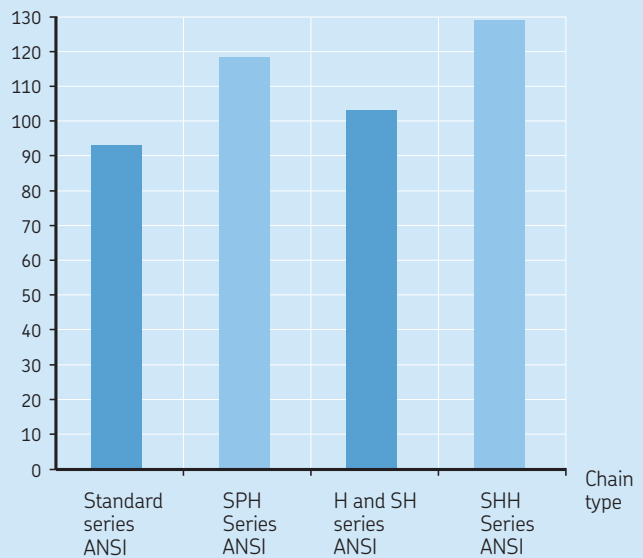



# SKF Xtra Strength H and BH chains

SKF Xtra Strength H and BH chains differ from the respective ANSI and BS/DIN chains slightly, due to using the plate thickness of the next larger size of ANSI roller chains. Therefore, H and BH series chains can accommodate approximately 10% higher shock loads. The ultimate tensile strength will be the same as a standard ANSI chain. SKF Xtra Strength H and BH chains are well suited for applications where shock loads are higher, operating speeds are lower or there are other severe operating conditions.

C

Table 1

## SKF Xtra Strength H &amp; BH Chains

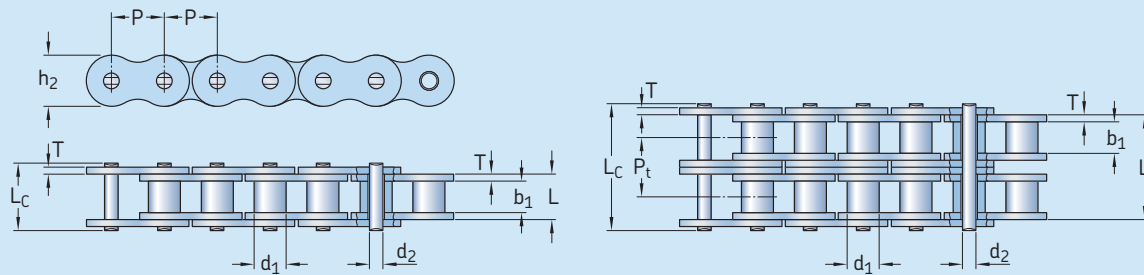

ANSI Chain number	BS/ISO Chain number	Dimensions					P. length cottered	Inner pl. height	Plate thickness	Transv. pitch	Ultimate tensile strength	Average tensile strength	Weight per meter	Designation	
		Pitch	Roller diameter	Width between inner plates	Pin diameter	Pin length									
		P	d <sub>1</sub> max	b <sub>1</sub> min	d <sub>2</sub> max	L max	L <sub>c</sub> max	L <sub>c</sub> max	h <sub>2</sub> max	T max	P <sub>t</sub>	Q min	Q <sub>0</sub>	q	
		mm										kN	kg/m	-	
35H-1*	-	9,525	5,08	4,77	3,58	13,3	14,3	-	9,0	1,50	-	7,9	10,8	0,41	PHC 35H-1...
40H-1	08AH-1	12,700	7,95	7,85	3,96	18,8	19,9	-	12,00	2,03	-	14,1	19,1	0,82	PHC 40H-1...
50H-1	10AH-1	15,875	10,16	9,40	5,08	22,1	23,4	24,4	15,09	2,42	-	22,2	30,2	1,25	PHC 50H-1...
60H-1	12AH-1	19,050	11,91	12,57	5,94	29,2	31,0	31,6	18,00	3,25	-	31,8	42,7	1,87	PHC 60H-1...
80H-1	16AH-1	25,400	15,88	15,75	7,92	36,2	37,7	39,4	24,00	4,00	-	56,7	71,4	3,10	PHC 80H-1...
100H-1	20AH-1	31,750	19,05	18,90	9,53	43,6	46,9	46,9	30,00	4,80	-	88,5	112,4	4,52	PHC 100H-1...
120H-1	24AH-1	38,100	22,23	25,22	11,10	53,5	57,5	57,5	35,70	5,60	-	127,0	160,9	6,60	PHC 120H-1...
140H-1	28AH-1	44,450	25,40	25,22	12,70	57,6	62,2	62,2	41,00	6,40	-	172,4	217,3	8,30	PHC 140H-1...
160H-1	32AH-1	50,800	28,58	31,55	14,27	68,2	73,0	73,0	47,80	7,20	-	226,8	285,8	10,30	PHC 160H-1...
180H-1	36AH-1	57,150	35,71	35,48	17,46	75,9	81,6	-	53,60	8,0	-	281,0	341,8	14,83	PHC 180H-1...
200H-1	40AH-1	63,500	39,68	37,85	19,85	86,6	93,5	93,5	60,00	9,50	-	353,8	444,5	19,16	PHC 200H-1...
240H-1	48AH-1	76,200	47,63	47,35	23,81	109,6	115,9	-	72,30	12,70	-	510,3	622,5	30,4	PHC 240H-1...
60H-2	12AH-2	19,050	11,91	12,57	5,94	55,3	57,1	57,7	18,00	3,25	26,11	63,6	84,5	3,71	PHC 60H-2...
80H-2	16AH-2	25,400	15,88	15,75	7,92	68,8	70,3	72,0	24,00	4,00	32,59	113,4	145,3	6,15	PHC 80H-2...
100H-2	20AH-2	31,750	19,05	18,90	9,53	82,7	86,0	86,0	30,00	4,80	39,09	177,0	225,9	9,03	PHC 100H-2...
120H-2	24AH-2	38,100	22,23	25,22	11,10	102,4	106,4	106,4	35,70	5,60	48,87	254,0	322,7	13,13	PHC 120H-2...
140H-2	28AH-2	44,450	25,40	25,22	12,70	109,8	114,4	114,4	41,00	6,40	52,20	344,8	437,7	16,60	PHC 140H-2...
160H-2	32AH-2	50,800	28,58	31,55	14,27	130,1	134,9	134,9	47,80	7,20	61,90	453,6	571,6	20,20	PHC 160H-2...
200H-2	40AH-2	63,500	39,68	37,85	19,85	164,9	171,8	171,8	60,00	9,50	78,31	707,6	894,9	38,11	PHC 200H-2...
60H-3	12AH-3	19,050	11,91	12,57	5,94	81,4	83,2	83,8	18,00	3,25	26,11	95,4	113,9	5,54	PHC 60H-3...
80H-3	16AH-3	25,400	15,88	15,75	7,92	101,4	102,9	104,6	24,00	4,00	32,59	170,1	203,5	9,42	PHC 80H-3...
100H-3	20AH-3	31,750	19,05	18,90	9,53	121,8	125,1	125,1	30,00	4,80	39,09	265,5	314,8	12,96	PHC 100H-3...
120H-3	24AH-3	38,100	22,23	25,22	11,10	151,2	155,2	155,2	35,70	5,60	48,87	381,0	444,7	19,64	PHC 120H-3...
140H-3	28AH-3	44,450	25,40	25,22	12,70	162,0	166,6	166,6	41,00	6,40	52,20	517,2	598,4	24,90	PHC 140H-3...
160H-3	32AH-3	50,800	28,58	31,55	14,27	192,0	196,8	196,8	47,80	7,20	61,90	680,4	787,3	30,10	PHC 160H-3...
200H-3	40AH-3	63,500	39,68	37,85	19,85	243,2	250,1	250,1	60,00	9,50	78,31	1061,4	1228,2	57,06	PHC 200H-3...

\* Bushing chain: d<sub>1</sub> indicates external diameter of bushing

Standard lengths are 10 ft. and 5 m. To complete designation, add chain length. For example, a 5 m box of 160H-1 is PHC 160H-1X5MTR.

For links, add "C/L" for "connecting" and "O/L" for "offset" to the designation.

For cottered, add a "C" after the number of strands. For example 160H-1 with a cottered pin is designated PHC 160H-1C...

For heavy duty multistrand chain drives, special sprockets are needed due to differences in transverse pitch.

# SKF Xtra Strength BH Series

Table 1

BS/ISO Chain number	Dimensions						Inner plate height	Plate thickness	Ultimate tensile strength	Weight per meter	Designation
	Pitch	Roller diameter	Width between inner plates	Pin diameter	Pin length						
	P	d <sub>1</sub> max	b <sub>1</sub> max	d <sub>2</sub> max	L max	L <sub>c</sub> max	h <sub>2</sub> max	T max	Q min	q	
–	mm								kN	kg/m	–
<b>04BH</b>	6.000	4	2.8	1.85	8.4	9.4	5.00	0.9	5.0	0.14	<b>PHC 04BH-1...</b>
<b>068H*</b>	9.525	6.35	5.72	3.58	14.4	15.4	8.20	1.6	11.3	0.51	<b>PHC 06BH-1...</b>
<b>08BH</b>	12.7	8.51	7.85	4.45	18.8	19.9	11.80	2.3	20.6	0.79	<b>PHC 08BH-1...</b>
<b>10BH</b>	15.875	10.16	9.65	5.08	20.2	21.6	14.70	1.85	25	1.03	<b>PHC 10BH-1...</b>
<b>128H</b>	19.05	12.07	11.68	5.94	25.2	26.8	16.00	2.42	40	1.45	<b>PHC 12BH-1...</b>
<b>16BH</b>	25.4	15.88	17.02	8.9	35.7	38.9	24.10	4.0/3.1	80	3.11	<b>PHC 16BH-1...</b>
<b>24BH</b>	38.1	25.4	25.4	14.63	58.6	63.4	36.20	7.5/6.0	225	9	<b>PHC 24BH-1...</b>

\* Straight sidebar

# SKF Xtra Strength SH Chains

SKF Xtra Strength SH Chains have a 25–35% greater ultimate tensile strength than ANSI heavy duty roller chains due to their thicker plates and thru hardened pins. These chains can accommodate higher shock loads and provide longer service life, while retaining the same dimensions as ANSI heavy duty series roller chains.



*SKF Xtra Strength SH Chains used in the earthmoving industry*

## SKF Xtra Strength SH Chains

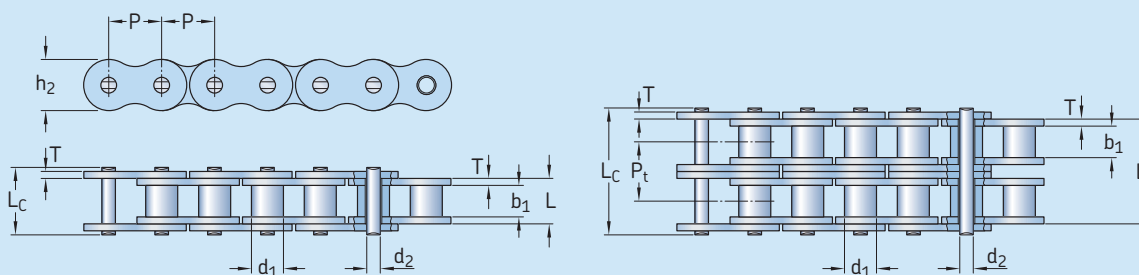

Chain number	Dimensions								Ultimate tensile strength	Average tensile strength	Weight per meter	Designation
	Pitch	Roller diameter	Width between inner plates	Pin diameter	Pin length	Inner plate height	Plate thickness					
	P	d <sub>1</sub> max	b <sub>1</sub> min	d <sub>2</sub> max	L max	L <sub>c</sub> max	h <sub>2</sub> max	T max	Q min	Q <sub>0</sub>	q	
	mm								kN		kg/m	
25SH-1*	6,35	3,3	3,18	2,01	9,0	–	6,00	2,01	5,09	5,6	2,17	PHC 25SH-1X...
35SH-1*	9,525	5,08	4,77	3,58	13,3	14,3	9,00	1,50	11,00	13,6	0,41	PHC 35SH-1X...
40SH-1	12,700	7,95	7,85	3,96	18,8	19,9	12,00	2,03	22,40	24,8	0,82	PHC 40SH-1X...
50SH-1	15,875	10,16	9,40	5,08	22,1	23,4	15,09	2,42	30,40	36,2	1,25	PHC 50SH-1X...
60SH-1	19,050	11,91	12,57	5,94	29,2	31,6	18,00	3,25	44,10	50,4	1,87	PHC 60SH-1X...
80SH-1	25,400	15,88	15,75	7,92	36,2	37,7	24,00	4,00	88,20	93,0	3,10	PHC 80SH-1X...
100SH-1	31,750	19,05	18,90	9,53	43,6	46,9	30,00	4,80	116,60	129,1	4,52	PHC 100SH-1X...
120SH-1	38,100	22,23	25,22	11,10	53,5	57,5	35,70	5,60	158,20	175,3	6,60	PHC 120SH-1X...
140SH-1	44,450	25,40	25,22	12,70	57,6	62,2	41,00	6,40	206,00	266,5	8,30	PHC 140SH-1X...
160SH-1	50,800	28,58	31,55	14,27	68,2	73,0	47,80	7,20	274,00	293,0	10,30	PHC 160SH-1X...
200SH-1	63,500	39,68	37,85	19,85	86,6	93,5	60,00	9,50	506,10	562,3	19,16	PHC 200SH-1X...

\* Bushing chain: d<sub>1</sub> indicates external diameter of bushing

Standard lengths are 10 ft. and 5 m. To complete designation, add chain length. For example, a 5 m box of 100SH-1 is PHC 100SH-1X5MTR.

For "connecting" links, add "C/L" to the designation.

For heavy duty multistrand chain drives, special sprockets are needed due to differences in transverse pitch.

# SKF Xtra Strength SPH Chains

SKF Xtra Strength SPH Chains have specially designed, close tolerance link plates and pitch holes. Their special design can improve load carrying capacity by 25–32%. The pins used on these chains are thru hardened for greater shock load resistance. The dimensions of these chains are the same as ANSI standard roller chains.



*SKF Xtra Strength SPH Chains used in the steel industry*

## SKF Xtra Strength SPH Chains

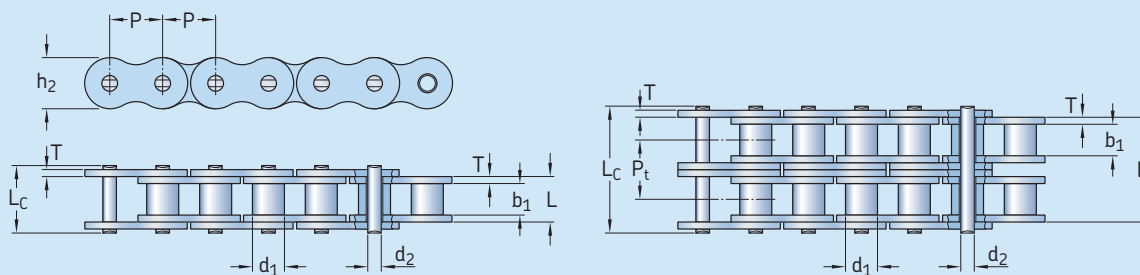

Chain number	Dimensions					Inner plate height	Plate thickness	Transverse pitch	Ultimate tensile strength	Average tensile strength	Weight per meter	Designation	
	Pitch	Roller diameter	Width between inner plates	Pin diameter	Pin length								
	P	d <sub>1</sub> max	b <sub>1</sub> min	d <sub>2</sub> max	L max	L <sub>c</sub> max	h <sub>2</sub> max	T max	P <sub>t</sub>	Q min	Q <sub>0</sub>	q	
	mm									kN	kg/m		
80SPH-1	25,400	15,88	15,75	7,94	32,7	36,5	24,10	3,20	–	77,5	85,3	2,86	PHC80SPH-1X...
100SPH-1	31,750	19,05	18,95	9,54	40,4	44,7	30,10	4,00	–	115,5	127,0	4,21	PHC100SPH-1X...
120SPH-1	38,100	22,23	25,22	11,11	50,3	54,3	36,20	4,80	–	165,0	186,0	6,36	PHC120SPH-1X...
140SPH-1	44,450	25,40	25,22	12,71	54,4	59,0	42,20	5,60	–	222,7	245,0	8,04	PHC140SPH-1X...
160SPH-1	50,800	28,58	31,55	14,29	64,8	69,6	48,20	6,40	–	285,5	314,0	10,80	PHC160SPH-1X...
200SPH-1	63,500	39,68	37,85	19,85	80,3	87,2	60,30	8,00	–	445,5	490,0	18,00	PHC200SPH-1X...
80SPH-2	25,400	15,88	15,75	7,94	62,7	65,8	24,10	3,20	29,29	155,0	170,6	5,68	PHC80SPH-2X...
100SPH-2	31,750	19,05	18,95	9,54	76,4	80,5	30,10	4,00	35,76	231,0	255,0	8,34	PHC100SPH-2X...
120SPH-2	38,100	22,23	25,22	11,11	95,8	99,7	36,20	4,80	45,44	339,0	373,0	12,63	PHC120SPH-2X...
140SPH-2	44,450	25,40	25,22	12,71	103,3	107,9	42,20	5,60	48,87	445,5	490,0	15,92	PHC140SPH-2X...
160SPH-2	50,800	28,58	31,55	14,29	123,3	128,1	48,20	6,40	58,55	571,0	628,0	21,43	PHC160SPH-2X...
200SPH-2	63,500	39,68	37,85	19,85	151,9	158,8	60,30	8,00	71,55	892,0	981,0	35,00	PHC200SPH-2X...
80SPH-3	25,400	15,88	15,75	7,94	91,7	95,1	24,10	3,20	29,29	232,5	255,9	8,18	PHC80SPH-3X...
100SPH-3	31,750	19,05	18,95	9,54	112,2	116,3	30,10	4,00	35,76	347,3	382,0	12,47	PHC100SPH-3X...
120SPH-3	38,100	22,23	25,22	11,11	141,4	145,2	36,20	4,80	45,44	508,0	559,0	18,90	PHC120SPH-3X...
140SPH-3	44,450	25,40	25,22	12,71	152,2	156,8	42,20	5,60	48,87	668,0	735,0	23,84	PHC140SPH-3X...
160SPH-3	50,800	28,58	31,55	14,29	181,8	186,6	48,20	6,40	58,55	855,5	941,0	32,10	PHC160SPH-3X...
200SPH-3	63,500	39,68	37,85	19,85	223,5	230,4	60,30	8,00	71,55	1336,4	1470,0	52,50	PHC200SPH-3X...

Standard lengths are 10 ft. and 5 m. To complete designation, add chain length. For example, a 5 m box of 100SPH-1 is PHC 100SPH-1X5MTR. For "connecting" links, add "C/L" to the designation.

# SKF Xtra Strength SHH Chains

SKF Xtra Strength SHH Chains use link plates that, in most cases, are equal in thickness to the plates used in the next larger size of SKF Xtra Strength SPH Chains. Its pins are also thru hardened. The use of higher grade materials results in chains that have greater ultimate tensile strength and allowable load than SKF Xtra Strength SH Chains.



*SKF Xtra Strength SHH Chains used in construction machinery*



## SKF Xtra Strength SHH Chains

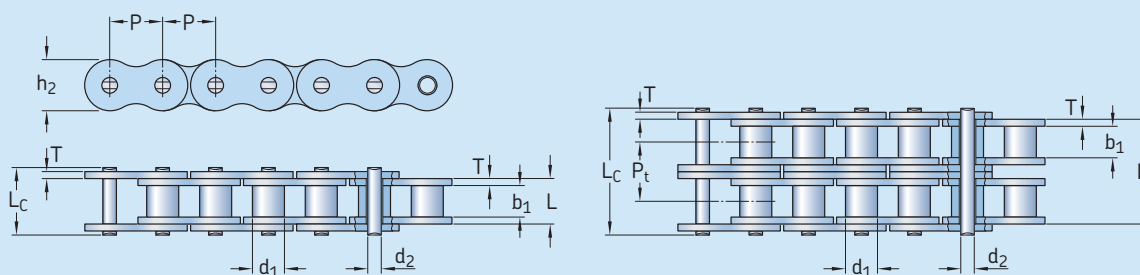

Chain number	Dimensions					Inner plate height	Plate thickness	Transverse pitch	Ultimate tensile strength	Average tensile strength	Weight per meter	Designation	
	Pitch	Roller diameter	Width between inner plates	Pin diameter	Pin length								
	P	d <sub>1</sub> max	b <sub>1</sub> min	d <sub>2</sub> max	L max	L <sub>c</sub> max	h <sub>2</sub> max	T max	P <sub>t</sub>	Q min	Q <sub>0</sub>	q	
	mm										kN	kg/m	-
<b>80SHH-1</b>	25,400	15,88	15,75	7,94	36,2	38,9	24,10	4,00	-	89,2	98,1	3,36	PHC 80SHH-1X...
<b>100SHH-1</b>	31,750	19,05	18,90	9,54	43,6	46,9	30,10	4,80	-	131,8	145,0	4,90	PHC 100SHH-1X...
<b>120SHH-1</b>	38,100	22,23	25,22	11,11	53,5	57,5	36,20	5,60	-	176,0	196,0	7,12	PHC 120SHH-1X...
<b>140SHH-1</b>	44,450	25,40	25,22	12,71	57,6	62,2	42,20	6,40	-	231,9	255,0	8,88	PHC 140SHH-1X...
<b>160SHH-1</b>	50,800	28,58	31,55	14,29	68,2	73,0	48,20	7,20	-	294,5	324,0	11,72	PHC 160SHH-1X...
<b>200SHH-1</b>	63,500	39,68	37,85	19,85	86,6	93,5	60,30	9,50	-	543,6	598,0	19,80	PHC 200SHH-1X...
<b>80SHH-2</b>	25,400	15,88	15,75	7,94	68,8	72,0	24,10	4,00	32,59	178,4	196,2	6,65	PHC 80SHH-2X...
<b>100SHH-2</b>	31,750	19,05	18,90	9,54	82,7	86,0	30,10	4,80	39,09	263,6	290,0	9,71	PHC 100SHH-2X...
<b>120SHH-2</b>	38,100	22,23	25,22	11,11	102,4	106,4	36,20	5,60	48,87	356,4	392,0	14,12	PHC 120SHH-2X...
<b>140SHH-2</b>	44,450	25,40	25,22	12,71	109,8	114,4	42,20	6,40	52,20	463,6	510,0	17,38	PHC 140SHH-2X...
<b>160SHH-2</b>	50,800	28,58	31,55	14,29	130,1	134,9	48,20	7,20	61,90	588,0	647,0	23,00	PHC 160SHH-2X...
<b>200SHH-2</b>	63,500	39,68	37,85	19,85	164,9	171,8	60,30	9,50	78,31	1091,0	1200,0	38,50	PHC 200SHH-2X...
<b>80SHH-3</b>	25,400	15,88	15,75	7,94	101,4	104,6	24,10	4,00	32,59	267,6	294,3	9,95	PHC 80SHH-3X...
<b>100SHH-3</b>	31,750	19,05	18,90	9,54	121,8	125,1	30,10	4,80	39,09	395,4	435,0	14,53	PHC 100SHH-3X...
<b>120SHH-3</b>	38,100	22,23	25,22	11,11	151,2	155,2	36,20	5,60	48,87	534,5	588,0	21,12	PHC 120SHH-3X...
<b>140SHH-3</b>	44,450	25,40	25,22	12,71	162,0	166,6	42,20	6,40	52,20	695,5	765,0	25,88	PHC 140SHH-3X...
<b>160SHH-3</b>	50,800	28,58	31,55	14,29	192,0	196,8	48,20	7,20	61,90	882,7	971,0	34,22	PHC 160SHH-3X...
<b>200SHH-3</b>	63,500	39,68	37,85	19,85	243,2	250,1	60,30	9,50	78,31	1627,3	1790,0	57,29	PHC 200SHH-3X...

Standard lengths are 10 ft. and 5 m. To complete designation, add chain length. For example, a 5 m box of 100SHH-1 is PHC 100SHH-1X5MTR.  
 For "connecting" links, add "C/L" to the designation in the table.  
 For heavy duty multistrand chain drives, special sprockets are needed due to differences in transverse pitch.

# SKF Engineered drive chains

Table 1

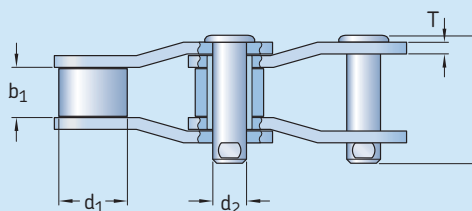
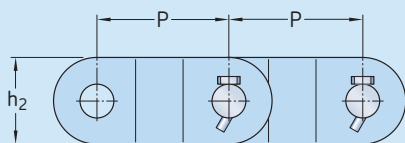

Chain number	Dimensions		Roller diameter	Width between inner plates	Pin diameter	Pin length	Plate height	Plate thickness	Ultimate tensile strength	Average tensile strength	Weight per meter	Designation
	Pitch											
	P		d <sub>1</sub> max	b <sub>1</sub> min	d <sub>2</sub> max	L max	h <sub>2</sub> max	T max	Q min	Q <sub>0</sub>	q	
	mm	inch							kN		kg/m	
PHC SS2065	50,8	2,000	28,58	32,5	15,05	79,5	38	7,9	220	242	12,14	PHC SS2065 ....
PHC R3112	50,80	2,000	28,7	31	14,20	73,9	41,4	6,4	168,9	185	10,70	PHC R3112 ....
PHC 2010	63,50	2,500	31,75	38,1	15,90	89,0	47,8	7,9	250	275	13,53	PHC 2010 ....
PHC 2010H	63,50	2,500	31,75	31,75	15,88	97,0	41,5	9,5	250	275	11,91	PHC 2010H ....
PHC SS588F1	66,27	2,609	22,23	27	11,11	62,0	28,6	6,4	88,9	98	5,39	PHC SS588F1 ....
PHC SS588F2	66,27	2,609	22,23	27	9,53	59,0	25,4	5,6	84,46	91	4,26	PHC SS588F2 ....
PHC MXS882	66,27	2,609	22,23	28,58	11,10	68,5	28,5	6,4	115,6	125	5,30	PHC MXS882 ....
PHC SS588	66,27	2,609	22,23	28,6	11,11	63,7	28,6	6,4	130	144	5,46	PHC SS588 ....
PHC MX603	76,20	3,000	22,5*	38	14,00	88	40	8,0	147	161	9,20	PHC MX603 ....
PHC 2512	77,90	3,067	41,28	39,6	19,05	100	57	9,7	340	367	18,40	PHC 2512 ....
PHC SS568H	77,90	3,067	41,3	39,7	19,05	97,6	57	9,5	340	367	19,80	PHC SS568H ....
PHC SS568HF2	77,90	3,067	41,3	39,7	19,05	98,5	57	9,5	447	491	16,90	PHC SS568HF2 ....
PHC 2512F2	77,90	3,067	41,28	38,5	19,05	103,4	60	10,0	400	420	20,28	PHC 2512F2 ....
PHC 2510F1	78,10	3,075	31,75	36,6	16,00	88,9	38,1	8,0	124,5	137	9,93	PHC 2510F1 ....
PHC 2510F2	78,10	3,075	31,75	36,6	15,75	88	38,1	8,0	225	248	11,70	PHC 2510F2 ....
PHC 2510	78,10	3,075	31,75	36,9	16,00	94,8	40	8,0	271	292	10,72	PHC 2510 ....
PHC 2510H	78,10	3,075	31,75	36,9	16,50	95,3	45	9,5	280	302	12,70	PHC 2510H ....
PHC MXS3075	78,10	3,075	31,75	38,1	16,46	93,5	44,5	9,7	334	360	13,45	PHC MXS3075 ....
PHC MXS3075F1	78,10	3,075	33	38,1	16,46	94,5	44,5	9,7	334	365	14,00	PHC MXS3075F1 ....
PHC MXS3075F2	78,10	3,075	31,75	38,1	17,81	90	45	8,0	333	365	12,20	PHC MXS3075F2 ....
PHC SS40H	78,11	3,075	31,75	38,1	15,88	97	41,5	9,5	250	280	12,60	PHC SS40H ....
PHC 2814	88,90	3,500	44,45	36,6	22,23	117,6	58	12,7	471	507	25,70	PHC 2814 ....
PHC 2814F1	88,90	3,500	44,45	36,9	22,23	117,6	60	13,5	556	611	24,20	PHC 2814F1 ....
PHC 2814F2	88,90	3,500	44,45	38,6	22,23	119,6	58	12,7	559	614	25,40	PHC 2814F2 ....
PHC 3214	103,20	4,063	44,45	48	22,00	123,5	55	13,0	476	514	23,60	PHC 3214 ....
PHC SS124	103,20	4,063	44,45	49,2	22,23	127,2	57	12,7	560	590	22,57	PHC SS124 ....
PHC MXS1242	103,20	4,063	44,45	49,2	22,23	124,5	57	12,8	623	672	24,63	PHC MXS1242 ....
PHC 3214F1	103,20	4,063	44,45	49,2	23,90	129	60	14,0	666,4	700	26,70	PHC 3214F1 ....
PHC 3315	t103,45	4,073	45,24	49,3	23,85	130	63,5	14,2	550	594	27,71	PHC 3315 ....
PHC SS1245	103,45	4,073	45,2	49,6	23,80	129,4	60	14,5	550	605	31,19	PHC SS1245 ....
PHC SH1245	103,45	4,073	45,3	49,6	23,80	130	60	14,5	722	794	31,00	PHC SH1245 ....
PHC SS15F1	103,45	4,073	45,24	47,9	23,85	133	60	15,0	650	616	27,34	PHC SS15F1 ....
PHC 3618	114,30	4,500	57,15	52,3	27,97	138	79,2	14,2	760	820	41,20	PHC 3618 ....
PHC SS635H	114,30	4,500	57,2	52,4	27,94	137	76,2	14,5	760	836	37,80	PHC SS635H ....
PHC SS635HF1	114,30	4,500	57,2	52,4	27,94	137	76,2	17,5	964	1 060	37,90	PHC SS635HF1 ....
PHC R01205	127,00	5,000	63,5	65	31,75	147,6	82,5	14,2	872	955	42,93	PHC R01205 ....
PHC 4020	t127,00	5,000	63,5	69,9	31,78	165,7	88,9	15,7	987	1 069	48,60	PHC 4020 ....
PHC 4020SH	127,00	5,000	63,5	69,9	31,78	165,7	88,9	15,7	1332	1 246	48,60	PHC 4020SH ....
PHC F2184 1	152,40	6,000	76,2	35	22,20	96	51	9,5	330	356	18,17	PHC F2184 ....
PHC A2184 1	152,40	6,000	76,2	35	22,20	96	51	9,5	330	330	18,17	PHC A2184 ....
PHC N2184 1	152,40	6,000	76,2	35	22,20	96	51	9,5	330	320	18,17	PHC N2184 ....
PHC R06042F1	152,40	6,000	76,2	76,3	44,00	184	120	19,0	1500	1 600	63,60	PHC R06042F1 ....
PHC 4824	152,40	6,000	76,2	74,6	38,10	186	100	20,0	1600	1 700	69,80	PHC 4824 ....

\* Bush Diameter external dimension  
Prefix F - Standard materials; Prefix A - Stainless steel bush & pin only; Prefix N - Nickel plated bush & pin only

# SKF Xtra Performance SLR Chains

The method of achieving internal lubrication of the chains is known as sintering and consists of the high quality oil impregnation of the components during their manufacture. The steel bushings are forged with lubricant within the material structure of the steel. During this operation, the lubricant forms a micro thin layer between the pin and internal roller surfaces.

Self-lubricating chains provide excellent service life without relubrication. In addition, self-lubricating chain pins are nickel-plated to provide a very smooth running surface that will not cause the self-lubricating bushings to wear. The link plates are black phosphate coated. Self-lubricating chains are interchangeable with standard roller chains.

The use of self-lubricating chains can substantially reduce elongation in many applications. This provides an increased service life of the chain.

The SKF Xtra Performance SLR Chains can also be used as a base for attachment chains, which are commonly required in the printing and packaging industry.

## Application

As self-lubricating chains do not require lubricant, they are suitable for applications where lubrication is not possible or practical. Consequently, these chains offer a long-lasting maintenance-free solution. Contamination of the final product from oil spillage or oil mist is the primary reason for lubrication-free chains in the paper, packaging, electronics, white and brown goods manufacturing sectors. Altogether, if lubrication can be avoided, planned lubrication intervals are unnecessary and maintenance costs are reduced accordingly.



SKF Xtra Performance SLR Chains used on food processing machinery

SKF Xtra Performance SLR Chains vs standard chains

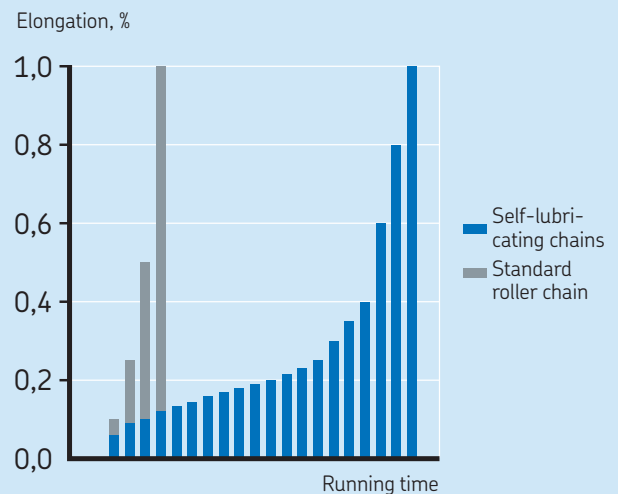

## SKF Xtra Performance SLR Chains

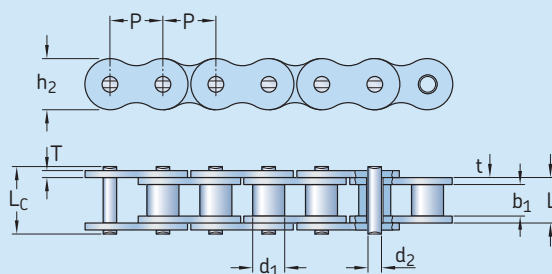

Chain number	Dimensions										Ultimate tensile strength	Weight per meter	Designation
	Pitch	Roller diameter	Width between inner plates	Width between outer plates	Pin diameter	Pin length	Plate height	Plate thickness					
	P	d <sub>1</sub> max	b <sub>1</sub> min	b <sub>2</sub> min	d <sub>2</sub> max	L max	L <sub>c</sub> max	h <sub>2</sub> max	t max	T max	Q min	q	
–	mm										kN	kg/m	–
<b>08B-1SLR</b>	12,70	8,51	7,75	13,03	4,45	18,3	19,8	11,8	1,60	1,60	18,0	0,73	PHC 08B-1SLR...
<b>10B-1SLR</b>	15,88	10,16	9,65	13,75	5,08	19,9	21,6	14,7	1,70	1,70	22,4	0,97	PHC 10B-1SLR...
<b>12B-1SLR</b>	19,05	12,07	11,68	15,75	5,72	22,5	24,2	16,0	1,85	1,85	29,0	1,20	PHC 12B-1SLR...
<b>16B-1SLR</b>	25,40	15,88	17,02	27,50	8,28	38,1	40,6	21,0	4,15	3,10	60,0	2,72	PHC 16B-1SLR...
<b>12B-2SLR</b>	19,05	12,07	11,68	35,21	5,72	42,0	43,6	16,0	1,85	1,85	58,0	2,42	PHC 12B-2SLR...
<b>16B-2SLR</b>	25,40	15,88	17,02	57,46	8,28	68,0	71,0	21,0	4,15	3,10	106,0	5,68	PHC 16B-2SLR...
<b>40-1SLR</b>	12,7	7,95	7,85	12,25	3,96	16,6	17,8	12,0	1,5	1,5	14,1	0,62	PHC 40-1SLR...
<b>50-1SLR</b>	15,88	10,16	9,40	13,84	5,03	20,7	22,2	15,1	2,03	2,03	21,8	1,12	PHC 50-1SLR...
<b>60-1SLR</b>	19,05	11,91	12,57	19,35	5,94	27,5	29,3	18,0	2,42	2,42	34,2	1,65	PHC 60-1SLR...
<b>80-1SLR</b>	25,40	15,88	15,75	22,66	7,92	32,7	35,0	24,0	3,25	3,25	56,7	2,63	PHC 80-1SLR...
<b>100-1SLR</b>	31,75	19,05	18,90	27,51	9,53	40,4	44,7	30,0	4,00	4,00	86,7	3,94	PHC 100-1SLR...
<b>60-2SLR</b>	19,05	11,91	12,57	42,13	5,94	50,3	52,1	18,0	3,25	2,42	68,4	3,21	PHC 60-2SLR...

Standard lengths are 10 ft. and 5 m. To complete designation, add chain length. For example, a 10 ft. box of 10B-1SLR is PHC 10B-1SLRX10FT. For links, add "C/L" for "connecting" and "O/L" for "offset" to the designation.

# SKF Side Bow Chains

Side bow (curved) chains are able to flex and twist due to extra clearance between the inner and outer side plates. They are ideal for use on curved conveyors or to transmit power under misaligned sprocket conditions. They are produced with barrel shaped pins and additional pin, bushing and link plate clearances. These features allow travel in a curved path and/or chain twist.

## Application

SKF Side Bow Chains are commonly used in curved track conveyors in the bottling, packaging, canning and textile industries.

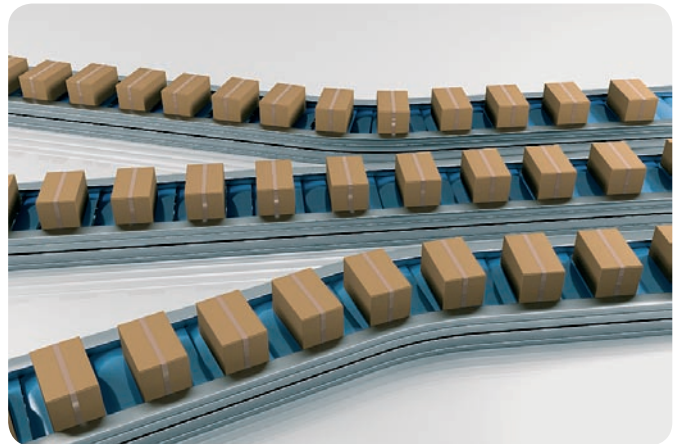

*SKF Xtra Performance SLR Chains used on food processing machinery*

## SKF Side Bow Chains

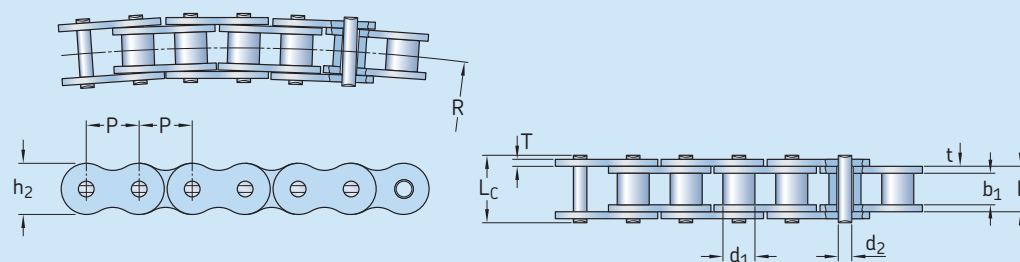

Chain number	Dimensions										Ultimate tensile strength	Average tensile strength	Weight per meter	Designation
	Pitch	Roller diameter	Width between inner plates	Pin diameter	Pin length		Inner plate height	Plate thickness	Side bow radius					
	P	d <sub>1</sub> max	b <sub>1</sub> min	d <sub>2</sub> max	L max	L <sub>c</sub> max	h <sub>2</sub> max	t max	T max	R min	Q min	Q <sub>0</sub>	q	
	mm											kN	kg/m	
<b>40-1SB</b>	12,70	7,95	7,85	3,96	16,9	18,1	11,7	1,50	1,50	350	13,8	15,2	0,80	PHC 40-1SB...
<b>43-1SB</b>	12,70	7,95	7,85	3,45	18,3	19,5	11,7	1,50	1,50	305	12,0	13,2	0,64	PHC 43-1SB...
<b>50-1SB</b>	15,88	10,16	9,40	4,37	20,7	22,7	14,9	2,03	2,03	400	20,6	22,7	1,09	PHC 50-1SB...
<b>60-1SB</b>	19,05	11,91	12,57	5,34	26,6	28,4	18,0	2,42	2,42	500	15,7	17,3	1,54	PHC 60-1SB...
<b>63-1SB</b>	19,05	11,91	12,68	5,08	28,8	30,6	17,2	2,42	2,03	350	12,5	20,0	1,40	PHC 63-1SB...
<b>80-1SB</b>	25,40	15,88	15,75	7,19	34,0	37,3	24,0	3,25	3,25	711	40,9	42,0	2,60	PHC 80-1SB...
<b>08B-1SB</b>	12,70	8,51	7,75	3,97	17,4	18,7	11,8	1,60	1,60	400	14,0	15,4	0,70	PHC 08B-1SB...
<b>10B-1SB</b>	15,88	10,16	9,65	4,50	20,1	21,5	14,7	1,70	1,70	400	15,6	17,2	0,93	PHC 10B-1SB...
<b>12B-1SB</b>	19,05	12,07	11,68	5,12	23,1	24,8	16,0	1,85	1,85	500	20,5	22,6	1,16	PHC 12B-1SB...
<b>C2050-1SB</b>	31,75	10,16	9,40	5,08	21,3	22,6	15,0	2,03	2,03	800	21,8	24,1	0,84	PHC C2050-1SB...

Standard lengths are 10 ft. and 5 m. To complete designation, add chain length. For example, a 5 m box of 60-1SB is PHC 60-1SBX5MTR. For links, add "C/L" for "connecting" and "O/L" for "offset" to the designation.

# SKF Hollow Pin Chains

SKF Hollow Pin Chains offer flexibility to end-users as cross rods or extended pins may be easily inserted. Ideal for setups where spacing of cross rods or pins must be changed frequently. These chains are available in carbon steel and stainless steel.



*SKF Hollow Pin Chains used on a newspaper conveyor*

## SKF Hollow Pin Chains

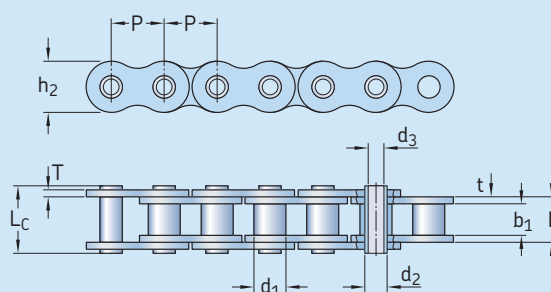

Chain number	Dimensions							Inner plate height	Plate thickness	Ultimate tensile strength	Average tensile strength	Weight per meter	Designation
	Pitch	Bush Diameter	Width between inner plate	Pin diameter		Pin length							
	P	d <sub>1</sub> max	b <sub>1</sub> min	d <sub>2</sub> max	d <sub>3</sub> max	L max	L <sub>c</sub> max	h <sub>2</sub> max	t/T max	Q min	Q <sub>0</sub>	q	
–	mm									kN		kg/m	–
<b>08BHP</b>	12,7	8,51	7,75	6,55	4,5	16,4	17,6	11,8	1,6/1,3	11,1/2523	12,1	0,56	<b>PHC 08B-1HP</b>
<b>10BHP</b>	15,875	10,16	9,65	7,02	5,13	19,5	20,5	14,7	1,7	10,0/2272	11,5	0,86	<b>PHC 10B-1HP</b>
<b>12BHP</b>	19,05	12,07	11,68	8,09	6	22,7	23,9	16,1	1,85	14,0/3180	16	0,82	<b>PHC 12B-1HP</b>
<b>16BHP</b>	25,4	15,88	17,02	11,5	8,2	35,3	37	23,2	4,0/3,1	49,0/11136	52,2	2,26	<b>PHC 16B-1HP</b>
<b>40HP</b>	12,7	7,95	7,85	5,63	4	16,5	17,6	12	1,5	11,0/2500	12,2	0,54	<b>PHC 40-1HP</b>
<b>50HP</b>	15,875	10,16	9,4	7,03	5,13	20,7	21,9	15,09	2,03	20,0/4545	22,6	0,91	<b>PHC 50-1HP</b>
<b>60HP</b>	19,05	11,91	12,7	8,31	6	25,8	26,8	18	2,42	24,0/5455	26,9	1,29	<b>PHC 60-1HP</b>
<b>80HP</b>	25,4	15,88	15,75	11,4	8,05	32,5	33,8	24	3,25	50,0/11364	52	2,26	<b>PHC 80-1HP</b>
<b>A2080HP</b>	50,8	15,88	15,75	11,4	8,05	32,4	33,8	24	3,25	42,3/9615	46,1	1,6	<b>PHC A2080HP</b>

Standard lengths are 10 ft. and 5 m. To complete designation, add chain length. For example, a 10 ft. box of 08-B-1HP is PHC 08B-1HPX10FT.



# SKF Straight Side Plate Chains

SKF Straight Side Plate Chains possess flat, rather than contoured link plates, for better sliding properties in conveyor applications. The fatigue strength and chain weight are slightly higher than for standard chains.

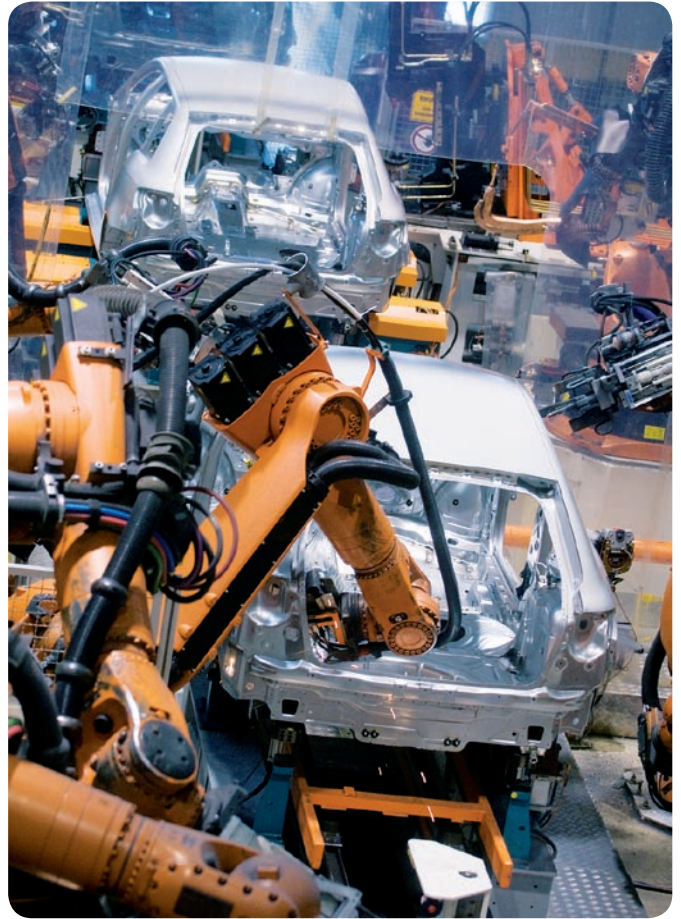

*SKF Straight Side Plate Chains used in the automotive industry*

## SKF Straight Side Plate Chain – A series

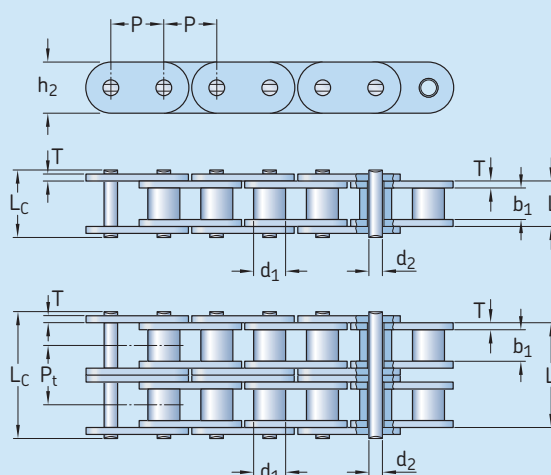

ISO Chain number	ANSI Chain number	Dimensions		Width between inner plates	Pin diameter	Pin length	Inner plate height	Plate thickness	Transverse pitch	Ultimate tensile strength	Average tensile strength	Weight per meter	Designation	
		Pitch	Roller diameter											
–	–	P	max	b <sub>1</sub> min	max	L max	L <sub>C</sub> max	h <sub>2</sub> max	T max	P <sub>t</sub>	Q min	Q <sub>0</sub>	q	–
–	–	mm										kN	kg/m	–
<b>C06A-1</b>	*C35	9,525	5,08	4,77	3,58	13,3	14,3	9	1,3	7,9	10,8	0,41	PHC C35-1...	
<b>C08A-1</b>	C40	12,7	7,95	7,85	3,96	16,6	18,8	12	1,5	14,1	17,5	0,73	PHC C40-1...	
<b>C10A-1</b>	C50	15,875	10,16	9,4	5,08	20,7	23,3	15,09	2,03	22,2	29,4	1,23	PHC C50-1...	
<b>C12A-1</b>	C60	19,05	11,91	12,57	5,94	28,3	18,0/18,2	2,42	31,8	41,5	1,81/1,83	3,09	PHC C60-1...	
<b>C16A-1</b>	C80	25,4	15,88	15,75	7,92	32,7	36,5	24	3,25	56,7	60,4	4,56	PHC C80-1...	
<b>C20A-1</b>	C100	31,75	19,05	18,9	9,53	40,4	44,7	30	4	88,5	109,2	6,86	PHC C100-1...	
<b>C24A-1</b>	C120	38,1	22,23	25,22	11,1	50,3	54,3	35,7	4,8	127,0	166,3	8,49	PHC C120-1...	
<b>C28A-1</b>	C140	44,45	25,4	25,22	12,7	54,4	59	41	5,6	172,4	212	11,5	PHC C140-1...	
<b>C32A-1</b>	C160	50,8	28,58	31,55	14,27	64,8	69,6	47,8	6,4	226,8	278,9	–	PHC C160-1...	
<b>C08A-2</b>	C40-2	12,7	7,95	7,85	3,96	31	33,2	12	1,5	14,38	28,2	1,43	PHC C40-2...	
<b>C10A-2</b>	C50-2	15,875	10,16	9,4	5,08	38,9	41,4	15,09	2,03	18,11	44,4	2,42	PHC C50-2...	
<b>C12A-2</b>	C60-2	19,05	11,91	12,57	5,94	48,8	51,1	18,0/18,2	2,42	22,78	63,6	3,58/3,62	PHC C60-2...	
<b>C16A-2</b>	C80-2	25,4	15,88	15,75	7,92	62,7	65,8	24	3,25	29,29	113,4	6,12	PHC C80-2...	
<b>C20A-2</b>	C100-2	31,75	19,05	18,9	9,53	76,4	80,5	30	4	35,76	177,0	9,08	PHC C100-2...	
<b>C34A-2</b>	C120-2	38,1	22,23	25,22	11,1	95,8	99,7	35,7	4,8	45,44	254,0	13,6	PHC C120-2...	
<b>C28A-2</b>	C140-2	44,45	25,4	25,22	12,7	103,3	107,9	41	5,6	48,87	344,8	16,86	PHC C140-2...	
<b>C32A-2</b>	C180-2	50,8	28,58	31,55	14,27	123,3	128,1	47,8	6,4	58,55	453,6	22,9	PHC C180-2...	
<b>C08A-3</b>	C40-3	12,7	7,95	7,85	3,96	45,4	47,6	12	1,5	14,38	42,3	2,14	PHC C40-3...	
<b>C10A-3</b>	C50-3	15,875	10,16	9,4	5,08	57	59,5	15,09	2,03	18,11	66,6	3,62	PHC C50-3...	
<b>C12A-3</b>	C60-3	19,05	11,91	12,57	5,94	71,5	73,9	18,0/18,2	2,42	22,78	95,4	5,36/5,41	PHC C60-3...	
<b>C16A-3</b>	C80-3	25,4	15,88	15,75	7,92	91,7	95,1	24	3,25	29,29	170,1	9,1	PHC C80-3...	
<b>C20A-3</b>	C100-3	31,75	19,05	18,9	9,53	112,2	116,3	30	4	35,76	265,5	13,6	PHC C100-3...	
<b>C24A-3</b>	C120-3	38,1	22,23	25,22	11,1	141,4	145,2	35,7	4,8	45,44	381,0	20,43	PHC C120-3...	
<b>C28A-3</b>	C140-3	44,45	25,4	25,22	12,7	152,2	156,8	41	5,6	48,87	517,2	25,23	PHC C140-3...	
<b>C32A-3</b>	C160-3	50,8	28,58	31,55	14,27	181,8	186,6	47,8	6,4	58,55	680,4	34,19	PHC C160-3...	

\* Bushing chain: d<sub>1</sub> in the table indicate the external diameter of the bushing.  
Standard lengths are 10 ft. and 5 m. To complete designation, add chain length. For example, a 10 ft. box of C08A-1 is PHC C08A-1X10FT.

Table 2

## SKF Straight Side Plate Chain – B series

DIN Chain number	Dimensions			Pin diameter	Pin length		Inner plate height	Plate thickness	Transverse pitch	Ultimate tensile strength	Average tensile strength	Weight per meter	Designation
	Pitch	Roller diameter	Width between inner plates		L max	L <sub>c</sub> max							
–	mm			–	–	–	–	–	–	kN	–	kg/m	–
<b>C08B-1</b>	12,7	8,51	7,75	4,45	16,7	18,2	11,8	1,6	–	18,0	19,5	0,8	PHC C08B-1...
<b>C10B-1</b>	15,875	10,16	9,65	5,08	19,5	20,9	14,7	1,7	–	22,4	27,9	1,06	PHC C10B-1...
<b>C12B-1</b>	19,06	12,07	11,68	5,72	22,5	25,2	16	1,85	–	29,0	32,2	1,32	PHC C12B-1...
<b>C16B-1</b>	25,4	15,88	17,02	8,28	36,1	39,1	21,0/24,0	4,15/3,1	–	60,0	72,8	3,08/3,49	PHC C16B-1...
<b>C20B-1</b>	31,75	19,05	19,56	10,19	41,3	45	26,4	4,5/3,5	–	95,0	106,7	4,16	PHC C20B-1...
<b>C24B-1</b>	38,1	25,4	25,4	14,63	53,4	57,8	33,2	6,0/4,8	–	160,0	178	7,47	PHC C24B-1...
<b>C28B-1</b>	44,45	27,94	30,99	15,9	66,1	69,5	36,7	7,5/6,0	–	200,0	222	9,9	PHC C28B-1...
<b>C32B-1</b>	50,8	29,21	30,99	17,81	66	71	42	7,0/6,0	–	250,0	277,5	10,45	PHC C32B-1...
<b>C08B-2</b>	12,7	8,51	7,75	4,45	31,2	32,2	11,8	1,6	13,92	32,0	38,7	1,45	PHC C08B-2...
<b>C10B-2</b>	15,875	10,16	9,65	5,08	36,1	37,5	14,7	1,7	16,59	44,5	57,8	2	PHC C10B-2...
<b>C12B-2</b>	19,05	12,07	11,68	5,72	42	44,7	16	1,85	19,46	57,8	66,1	2,62	PHC C12B-2...
<b>C16B-2</b>	25,4	15,88	17,02	8,28	68	71	21,0/24,0	4,15/3,1	31,88	106,0	133	6,10/6,92	PHC C16B-2...
<b>C20B-2</b>	31,75	19,05	19,56	10,19	77,8	81,5	26,4	4,5/3,5	36,45	170,0	211,2	8,23	PHC C20B-2...
<b>C24B-2</b>	38,1	25,4	25,4	14,63	101,7	106,2	33,2	6,0/4,8	48,36	280,0	319,2	14,77	PHC C24B-2...
<b>C28B-2</b>	44,45	27,94	30,99	15,9	124,6	129,1	36,7	7,5/6,0	59,56	360,0	406,8	19,82	PHC C28B-2...
<b>C32B-2</b>	50,8	29,21	30,99	17,81	124,6	129,6	42	7,0/6,0	58,65	450,0	508,5	20,94	PHC C32B-2...
<b>C08B-3</b>	12,7	8,51	7,75	4,45	45,1	46,1	11,8	1,6	13,92	47,5	57,8	2,1	PHC C08B-3...
<b>C10B-3</b>	15,875	10,16	9,65	5,08	52,7	54,1	14,7	1,7	16,59	66,7	84,5	2,87	PHC C10B-3...
<b>C12B-3</b>	19,05	12,07	11,66	5,72	61,5	64,2	16	1,85	19,46	86,7	101,8	3,89	PHC C12B-3...
<b>C16B-3</b>	25,4	15,88	17,02	8,28	99,8	102,9	21,0/24,0	4,15/3,1	31,88	160,0	203,7	9,12/10,34	PHC C16B-3...
<b>C20B-3</b>	31,75	19,05	19,56	10,19	114,2	117,9	26,4	4,5/3,6	36,45	250,0	290	11,34	PHC C20B-3...
<b>C24B-3</b>	38,1	25,4	25,4	14,63	150,1	154,6	33,2	6,0/4,8	48,36	425,0	493	22,1	PHC C24B-3...
<b>C28B-3</b>	44,45	27,94	30,99	15,9	184,2	188,7	36,7	7,5/6,0	59,56	530,0	609,5	29,64	PHC C28B-3...
<b>C32B-3</b>	50,8	29,21	30,99	17,81	183,2	188,2	42	7,0/6,0	58,55	670,0	770,5	31,27	PHC C32B-3...

Standard lengths are 10 ft. and 5 m. To complete designation, add chain length. For example, a 10 ft. box of C08B-1 is PHC C08B-1X10FT.

# Notes



A large grid of graph paper for taking notes, consisting of 20 columns and 30 rows of small squares.

# SKF Double Pitch Roller Chains

SKF Double Pitch Roller Chains are produced in accordance with the ASME/ANSI B29.3 (transmission series) and B29.4 (conveyor series) American roller chain standards. In general, these chains are dimensionally similar to ASME/ANSI standard products except that the pitch is double. They are available in the transmission and conveyor series with standard sized rollers, and additionally with large (oversize) rollers in the conveyor series. These chains are an economical choice for low speeds, moderate loads, and long centre distance drive applications including a variety of conveyor systems and material handling equipment.



*SKF Double Pitch Roller Chains used in agricultural applications*



Table 1

## Double Pitch Roller Chains

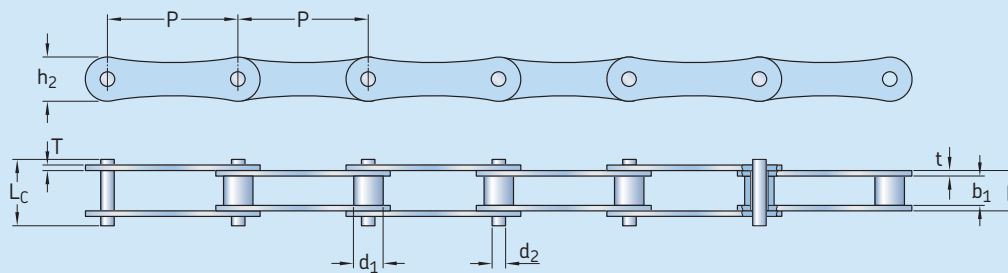

ANSI Chain number	BS/ISO Chain number	Dimensions									Ultimate tensile strength	Average tensile strength	Weight per meter	Designation
		Pitch	Roller diameter	Width between inner plates	Pin diameter	Pin length	Inner plate height	Plate thickness						
		P	d <sub>1</sub> max	b <sub>1</sub> min	d <sub>2</sub> max	L max	L <sub>c</sub> max	h <sub>2</sub> max	t max	T max	Q min	Q <sub>0</sub>	q	
		mm									kN		kg/m	
2040	208A	25,40	7,95	7,85	3,96	16,6	17,8	12,0	1,50	1,50	14,1	16,7	0,42	PHC 2040...
2050	210A	31,75	10,16	9,40	5,08	20,7	22,2	15,0	2,03	2,03	22,2	28,1	0,73	PHC 2050...
2060	212A	38,10	11,91	12,57	5,94	25,9	27,7	18,0	2,42	2,42	31,8	36,8	1,02	PHC 2060...
2080	216A	50,80	15,88	15,75	7,92	32,7	36,5	24,0	3,25	3,25	56,7	65,7	1,70	PHC 2080...
2100	220A	63,50	19,05	18,90	9,53	40,4	44,7	30,0	4,00	4,00	88,5	102,6	2,55	PHC 2100...
2120	224A	76,20	22,23	25,22	11,10	50,3	54,3	35,7	4,80	4,80	127,0	147,3	4,06	PHC 2120...
-	208B	25,40	8,51	7,75	4,45	16,7	18,2	11,8	1,60	1,60	18,0	19,4	0,45	PHC 208B...
-	210B	31,75	10,16	9,65	5,08	19,5	20,9	14,7	1,70	1,70	22,4	27,5	0,65	PHC 210B...
-	212B	38,10	12,07	11,68	5,72	22,5	25,2	16,0	1,85	1,85	29,0	32,2	0,76	PHC 212B...
-	216B	50,80	15,88	17,02	8,28	36,1	39,1	21,0	4,15	3,10	60,0	72,8	1,75	PHC 216B...
-	220B	63,50	19,05	19,56	10,19	41,3	45,0	26,4	4,50	3,50	95,0	106,7	2,62	PHC 220B...
-	224B	76,20	25,40	25,40	14,63	53,4	57,8	33,2	6,00	4,80	160,0	178,0	4,70	PHC 224B...
-	228B	88,90	27,94	30,99	15,90	65,1	69,5	36,7	7,50	6,00	200,0	222,0	6,23	PHC 228B...
-	232B	101,60	29,21	30,99	17,81	66,0	71,0	42,0	7,00	6,00	250,0	277,5	6,72	PHC 232B...

Standard lengths are 10 ft. and 5 m. To complete designation, add chain length. For example, a 5 m box of 2060 is PHC 2060X5MTR. For links, add "C/L" for "connecting" and "O/L" for "offset" to the designation.

## Transmission attachments

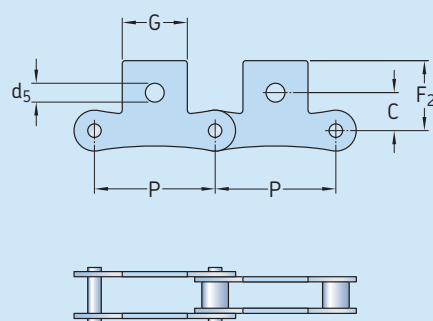
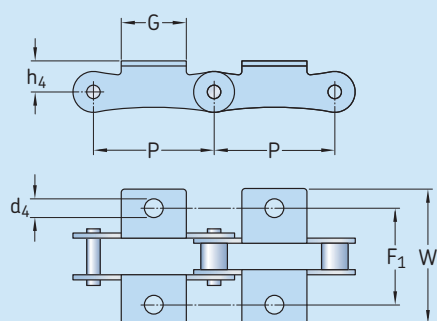

ANSI Chain number	BS/ISO Chain number			F <sub>1</sub>	W	h <sub>4</sub>	d <sub>4</sub>	C	F <sub>2</sub>	d <sub>5</sub>	Designation
		P	G								
–	–	mm									–
<b>2040</b>	208A	25,40	19,1	25,4	39,6	9,1	3,4	11,1	20,5	5,5	PHC 2040...
<b>2050</b>	210A	31,75	23,8	31,8	49,0	11,1	5,5	14,3	25,0	6,6	PHC 2050...
<b>2060</b>	212A	38,10	28,6	42,9	67,8	14,7	5,5	17,5	32,9	9,2	PHC 2060...
<b>2080</b>	216A	50,80	38,1	55,6	87,8	19,1	6,8	22,2	43,5	11,0	PHC 2080...
<b>2100</b>	220A	63,50	47,6	66,6	107,5	23,4	9,2	28,6	50,4	13,0	PHC 2100...
<b>2120</b>	224A	76,20	57,2	79,3	121,4	27,8	10,5	33,3	55,5	15,0	PHC 2120...
–	208B	25,40	23,2	25,4	39,6	9,1	4,5	11,1	20,5	5,5	PHC 208B...
–	210B	31,75	23,8	31,8	49,0	11,1	5,5	–	–	–	PHC 210B...
–	212B	38,10	35,0	38,1	57,0	14,7	6,6	–	–	–	PHC 212B...
–	216B	50,80	44,0	50,8	84,0	19,1	6,6	–	–	–	PHC 216B...
–	220B	63,50	52,0	63,5	104,0	23,4	8,4	–	–	–	PHC 220B...
–	224B	76,20	60,0	76,2	120,0	27,8	10,5	–	–	–	PHC 224B...

To complete designation, add attachment spacing and type followed by chain length.  
 For example: PHC 2060-L1K1X10FT (2060 chain with K-1 attachment on every link, 10 ft. (length)).  
 Note: Also available in stainless steel. When ordering, add SS after the chain number. For example: PHC 2060SS-L1K1X10FT.  
 For links, add "C/L" for "connecting" and "O/L" for "offset" to the designation.

# SKF Agricultural chains

The SKF agricultural range of chains are used extensively in the general agricultural industry for either light duty drive chains, or with a range of optional attachments, (typically K and A types) are used for conveyor drives and elevators.

Applications may include combined harvesters, grain elevators, grading machines, balers, amongst others. They may also be used on light duty elevator applications.

The SKF series interchanges with the industry standards in use today. Special treatments such as zinc plating are available on request.



## S Type Steel Agricultural Roller Chains (standard series)

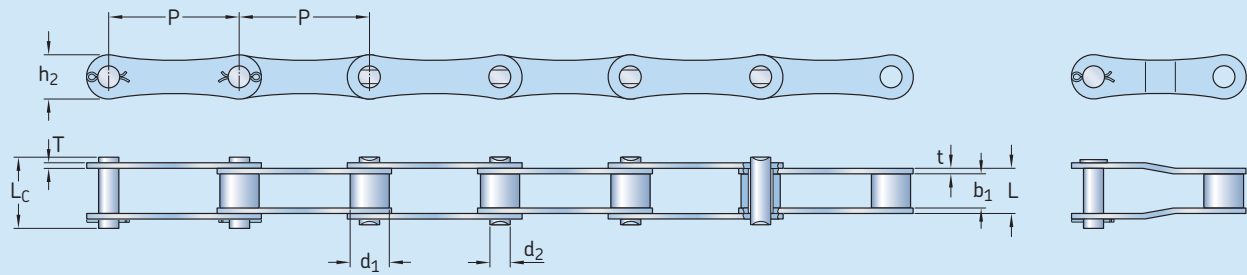

SKF Chain number	Dimensions		Roller diameter	Width between inner plates	Pin diameter	Pin length		Inner plate height	Plate thickness		Ultimate tensile strength	Average tensile strength	Weight per meter	Designation
	Pitch					L max	L <sub>c</sub> max		t max	T max				
	P		d <sub>1</sub> max	b <sub>1</sub> min	d <sub>2</sub> max	L max	L <sub>c</sub> max	h <sub>2</sub> max	t max	T max	Q min	Q <sub>0</sub>	q	
–	mm	inch	mm								kN		kg/m	–
<b>S32</b>	29,21	1,15	11,43	15,88	4,45	26,7	28,8	13,2	1,8	1,8	8,0	21,6	0,86	PHC S32X...
<b>S42</b>	34,93	1,38	14,27	19,05	7,0	34,3	37,0	19,8	2,8	2,8	27,0	50,8	1,6	PHC S42X...
<b>S45</b>	41,4	1,63	15,24	22,23	5,72	37,7	40,4	17,3	2,8	2,8	18,0	36,1	1,66	PHC S45X...
<b>S52</b>	38,1	1,50	15,24	22,23	5,72	37,7	40,4	17,3	2,8	2,8	18,0	36,1	1,68	PHC S52X...
<b>S55</b>	41,4	1,63	17,78	22,23	5,72	37,7	40,4	17,3	2,8	2,8	18,0	36,1	1,8	PHC S55X...
<b>S62</b>	41,91	1,65	19,05	26,2	5,72	40,3	43,0	17,3	2,5	2,5	26,7	36,1	1,87	PHC S62X...
<b>S77</b>	58,34	2,30	18,26	22,23	8,9	43,2	46,4	26,2	4,0	4,0	45,0	73,1	2,66	PHC S77X...
<b>S88</b>	66,27	2,61	22,86	28,58	8,9	49,8	53,0	26,2	4,0	4,0	45,0	73,1	3,25	PHC S88X...

# SKF Silent Chains

SKF Silent Chains (or inverted tooth chains) are manufactured to comply with GB10855 (equivalent to SC Series silent chains ANSI B29.2M), which are most commonly used for industrial applications. All silent chains are made up of stacked rows of flat, tooth shaped driving links that mesh with sprockets having compatible tooth spaces, similar to a rack and pinion mesh. Typically, chains will also contain guide links, whose purpose is to maintain proper tracking of the chain on the sprockets. Washers or spacers may be present in some chain constructions. All of these components are held together by riveted pins located at each chain joint end. Pin and rocker joint design minimizes heat and allows for low wear rates during power transmission. These chains transmit power smoothly, efficiently and economically.

## Application

SKF Silent Chains offer unique advantages and options in both power transmission and conveying applications. In power transmission applications, silent chains are capable of transmitting loads and speeds that exceed the capability of all other chains and belts. Drives are compact and efficient, operating with little noise or vibration. In conveying applications, silent chains provide a durable, heat resistant, non-slip, flat, conveying surface that runs with a nearly constant linear velocity.

## Flank contact

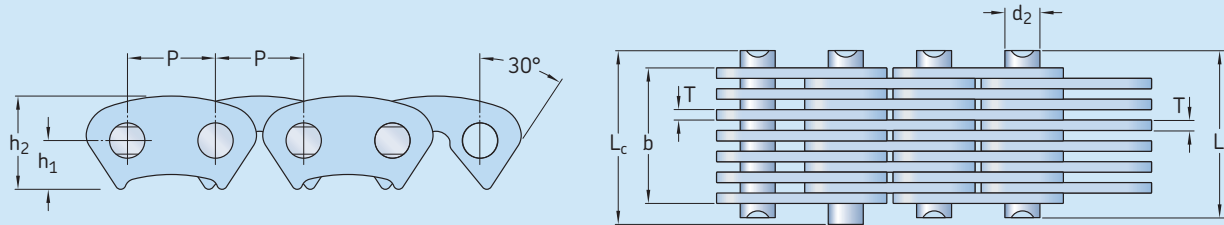

Chain number	Dimensions					Distance from hole center to tooth	Plate height	Plate thickness	Guide form	Number of plates	Ultimate tensile strength	Average tensile strength	Weight per meter	Designation
	Pitch	Chain width	Pin diameter	Pin length	Pin length									
	P	b min	d <sub>2</sub> max	L max	L <sub>c</sub> max	h <sub>1</sub>	h <sub>2</sub> max	T max		n	Q min	Q <sub>0</sub>	q	
	mm	mm									kN		kg/m	
CL06-13,5	9,525	13,5	3,95	18,5	20,0	5,3	10,0	1,5	Outside	9	10,0	11,2	0,60	PHC CL06-13.5...
CL06-16,5		16,5		21,5	23,0				Outside	11	12,5	14,0	0,73	PHC CL06-16.5...
CL06-19,5		19,5		24,5	26,0				Outside	13	15,0	16,8	0,85	PHC CL06-19.5...
CL06-22,5		22,5		27,5	29,0				Outside	15	17,5	19,6	1,00	PHC CL06-22.5...
CL06-28,5		28,5		33,5	35,0				Inside	19	22,5	25,2	1,26	PHC CL06-28.5...
CL08-19,5	12,700	19,5	5,08	24,5	26,0	7,0	13,4	1,5	Outside	13	23,4	26,2	1,15	PHC CL08-19.5...
CL08-22,5		22,5		27,5	29,0				Outside	15	27,4	30,6	1,33	PHC CL08-22.5...
CL08-25,5		25,5		30,5	32,0				Outside	17	31,3	35,0	1,50	PHC CL08-25.5...
CL08-28,5		28,5		33,5	35,0				Inside	19	35,2	39,4	1,68	PHC CL08-28.5...
CL08-34,5		34,5		39,5	41,0				Inside	23	43,0	48,1	2,04	PHC CL08-34.5...
CL08-40,5		40,5		45,5	47,0				Inside	27	50,8	56,8	2,39	PHC CL08-40.5...
CL08-46,5		46,5		51,5	53,0				Inside	31	58,6	65,6	2,74	PHC CL08-46.5...
CL08-52,5		52,5		57,5	59,0				Inside	35	66,4	74,3	3,10	PHC CL08-52.5...
CL10-30,0	15,875	30,0	5,92	37,0	38,2	8,7	16,7	2,0	Inside	15	45,6	50,6	2,21	PHC CL10-30.0...
CL10-38,0		38,0		45,0	46,2				Inside	19	58,6	65,0	2,80	PHC CL10-38.0...
CL10-46,0		46,0		53,0	54,2				Inside	23	71,7	79,5	3,39	PHC CL10-46.0...
CL10-54,0		54,0		61,0	62,4				Inside	27	84,7	94,0	3,99	PHC CL10-54.0...
CL10-62,0		62,0		69,0	70,4				Inside	31	97,7	108,4	4,58	PHC CL10-62.0...
CL12-38,0	19,050	38,0	6,90	45,0	46,5	10,5	20,0	2,0	Inside	19	70,0	77,6	3,37	PHC CL12-38.0...
CL12-46,0		46,0		53,0	54,5				Inside	23	86,0	95,4	4,08	PHC CL12-46.0...
CL12-54,0		54,0		61,0	62,8				Inside	27	102,0	113,2	4,78	PHC CL12-54.0...
CL12-62,0		62,0		69,0	70,8				Inside	31	117,0	129,8	5,50	PHC CL12-62.0...
CL12-70,0		70,0		77,0	78,8				Inside	35	133,0	147,6	6,20	PHC CL12-70.0...
CL16-45,0	25,400	45,0	8,90	52,0	53,5	14,0	26,7	3,0	Inside	15	111,0	123,2	5,31	PHC CL16-45.0...
CL16-51,0		51,0		58,0	59,5				Inside	17	125,0	138,7	6,02	PHC CL16-51.0...
CL16-57,0		57,0		64,0	65,5				Inside	19	141,0	156,5	6,37	PHC CL16-57.0...
CL16-69,0		69,0		76,2	77,7				Inside	23	172,0	190,9	8,15	PHC CL16-69.0...
CL16-81,0		81,0		88,2	89,7				Inside	27	203,0	225,3	9,57	PHC CL16-81.0...
CL16-93,0		93,0		100,2	101,7				Inside	31	235,0	260,8	10,98	PHC CL16-93.0...
CL20-57,0	31,750	57,0	10,84	66,6	69,6	17,5	33,4	3,0	Inside	19	165,0	183,1	8,42	PHC CL20-57.0...
CL20-69,0		69,0		78,6	81,6				Inside	23	201,0	223,1	10,19	PHC CL20-69.0...
CL20-81,0		81,0		90,6	93,6				Inside	27	237,0	263,2	11,96	PHC CL20-81.0...
CL20-93,0		93,0		102,6	105,6				Inside	31	273,0	303,0	13,73	PHC CL20-93.0...
CL20-105,0		105,0		114,6	117,6				Inside	35	310,0	341,0	15,50	PHC CL20-105.0...
CL20-117,0		117,0		126,6	129,6				Inside	39	346,0	380,6	17,27	PHC CL20-117.0...

Standard lengths are 10 ft. and 5 m. To complete designation, add chain length. For example, a 5 m box of CL06-13.5 is PHC CL06-13.5X5MTR.

## Crotch contact

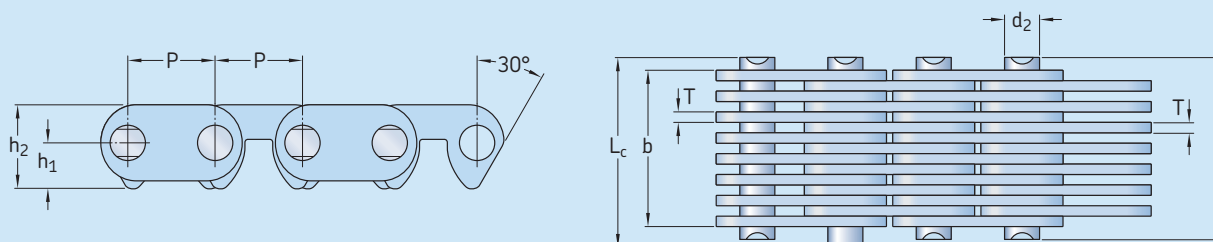

Chain number	Dimensions		Pin diameter	Pin length		Distance from hole height center to tooth		Plate thickness	Guide form	Number of plates	Ultimate tensile strength	Average tensile strength	Weight per meter	Designation
	Pitch	Chain width		L max	Lc max	h1	h2 max							
	P	b min	d2 max	L max	Lc max	h1	h2 max	T max			Q min	Q0	q	
–	mm								–		kN		kg/m	–
<b>C4-120</b>	12,7	19,5	5,08	24,5	26,0	6,62	12,1	1,5	Inside	13	20,0	22,2	1,20	<b>PHC C4-120...</b>
<b>C4-123</b>		22,5		27,5	29,0				Inside	15	23,0	25,5	1,37	<b>PHC C4-123...</b>
<b>C4-129</b>		28,5		33,5	35,0				Inside	19	28,5	31,6	1,72	<b>PHC C4-129...</b>
<b>C4-132</b>		31,5		35,5	38,0				Inside	21	31,5	34,9	1,89	<b>PHC C4-132...</b>
<b>C4-138</b>		37,5		42,5	44,0				Inside	25	38,0	42,1	2,22	<b>PHC C4-138...</b>
<b>C4-150</b>		49,5		54,5	56,0				Inside	33	50,0	55,5	2,90	<b>PHC C4-150...</b>
<b>C4-320</b>	12,7	19,5	5,08	24,5	26,0	6,62	12,1	1,5	Outside	13	20,0	22,2	1,21	<b>PHC C4-320...</b>
<b>C4-323</b>		22,5		27,5	29,0				Outside	15	23,0	25,5	1,38	<b>PHC C4-323...</b>
<b>C4-329</b>		28,5		33,5	35,0				Outside	19	28,5	31,6	1,73	<b>PHC C4-329...</b>
<b>C4-332</b>		31,5		36,5	38,0				Outside	21	31,5	34,9	1,90	<b>PHC C4-332...</b>
<b>C4-338</b>		37,5		42,5	44,0				Outside	25	38,0	42,1	2,23	<b>PHC C4-338...</b>

Standard lengths are 10 ft. and 5 m. To complete designation, add chain length. For example, a 5 m box of C4-120 is PHC C4-120X5MTR.

# SKF PIV Chains (Self forming tooth chains)

SKF PIV Chains (positive infinitely variable chains) comply with the ZBJ18003-89 standard for the application of chain driven gear boxes. These chains are used for the roller type infinite speed variators of the textile industry, on automotive variable speed drives as well as in variable pitch V grooves.



Table 1

Heading here?

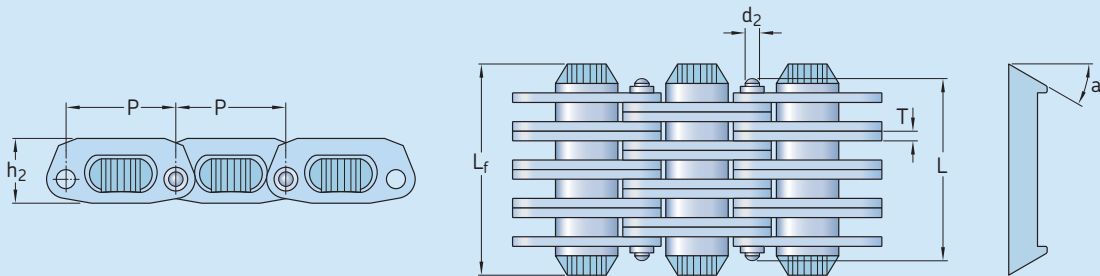

Chain number	Dimensions							Ultimate tensile strength	Average tensile strength	Weight per meter	Designation
	Pitch	Pin diameter	Pin length	Plate height	Plate thickness	Width over friction plates	Angle of friction plates				
-	P	d <sub>2</sub> max	L max	h <sub>2</sub> max	T max	L <sub>f</sub>	a	Q min	Q <sub>0</sub>	q	-
-	mm							kN/LB	kN	kg/m	-
A0	18,75	3	19,5	9,5	1	24	15°	9,0/2045	9,9	1	PHC A0
A1	25	3	30,1	13,5	1,5	37,8	15°	21,0/4772	23,3	2,23	PHC A1
A3	28,6	3	35,3	16	1,5	44,2	15°	38,5/8750	42,7	3,04	PHC A3
A4	36	4	48,5	20,5	1,5	58,5	15°	61,5/13977	68,2	5,54	PHC A4
A5	36	4	60,5	20,5	1,5	70	15°	71,0/16136	78,8	6,7	PHC A5

Standard lengths are 10 ft. and 5 m. To complete designation, add chain length. For example, a 5 m box of A1 is PHC A1X5MTR.

# SKF Oil Field Chains

SKF Oil Field Chains are used in oil industry applications where extreme loads and harsh operating conditions occur. These chains are manufactured according to API specifications and are designed to withstand heavy shock loads and extreme drive conditions.

Installation and maintenance are easy and simple. Oil field chains have distinctive “crook shank” pins to allow for easy assembly and dismantling.

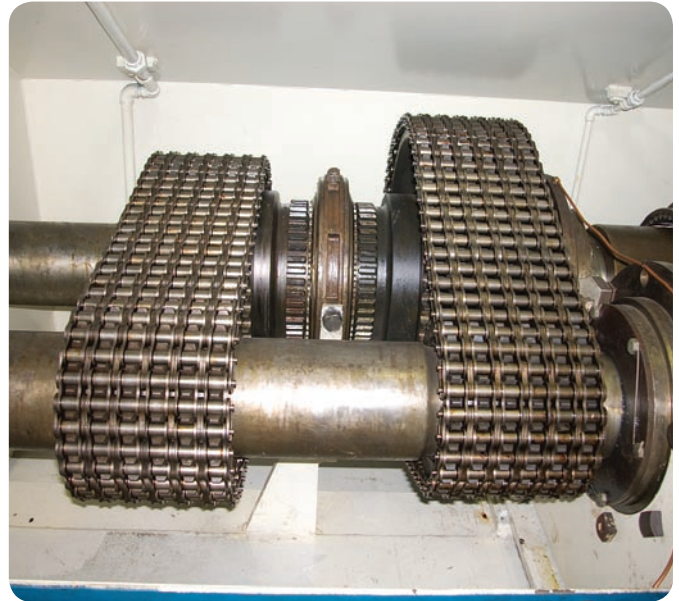

*Multiple strands of SKF Oil Field Chains inside a mud pump*

Table 1

## SKF Oil Field Chains

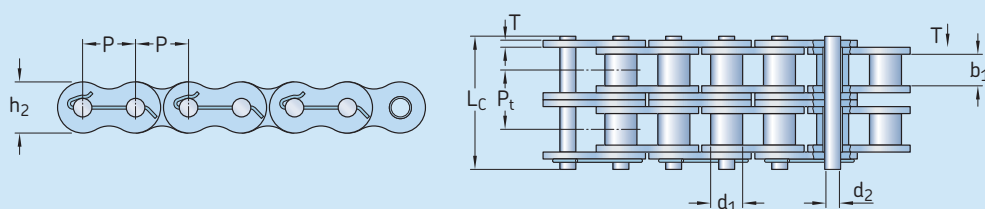

Chain number	ANSI Chain number	Dimensions								Ultimate tensile strength	Weight per meter	Designation	
		Pitch	Roller diameter	Width between inner plates	Pin diameter	Pin length	Inner plate height	Plate thickness	Transverse pitch				
		P	d <sub>1</sub> max	b <sub>1</sub> min	d <sub>2</sub> max	L <sub>c</sub> max	h <sub>2</sub> max	T max	P <sub>t</sub>	Q min	q		
		mm									kN	kg/m	-
16S-1	80-1	25,400	15,88	15,75	7,92	37,55	24,1	3,25	-	55,6	2,60	PHC 16S-1...	
20S-1	100-1	31,750	19,05	18,90	9,53	44,3	30,0	4,00	-	86,9	3,91	PHC 20S-1...	
24S-1	120-1	38,100	22,23	25,22	11,10	54,4	36,2	4,80	-	125,1	5,62	PHC 24S-1...	
28S-1	140-1	44,450	25,40	25,22	12,70	59,0	42,2	5,60	-	170,3	7,50	PHC 28S-1...	
32S-1	160-1	50,800	28,58	31,55	14,27	69,6	48,2	6,40	-	222,4	10,10	PHC 32S-1...	
36S-1	180-1	57,150	35,71	35,48	17,46	78,6	54,3	7,20	-	281,5	13,45	PHC 36S-1...	
40S-1	200-1	63,500	39,68	37,85	19,85	87,2	60,3	8,00	-	347,5	16,15	PHC 40S-1...	
16S-2	80-2	25,400	15,88	15,75	7,92	66,8	24,1	3,25	29,29	111,2	5,15	PHC 16S-2...	
20S-2	100-2	31,750	19,05	18,90	9,53	80,5	30,1	4,00	35,76	173,7	7,80	PHC 20S-2...	
24S-2	120-2	38,100	22,23	25,22	11,10	99,7	36,2	4,80	45,44	250,2	11,70	PHC 24S-2...	
28S-2	140-2	44,450	25,40	25,22	12,70	107,8	42,2	5,60	48,87	340,5	15,14	PHC 28S-2...	
32S-2	160-2	50,800	28,58	31,55	14,27	127,5	48,2	6,40	58,55	444,8	20,14	PHC 32S-2...	
36S-2	180-2	57,150	35,71	35,48	17,46	144,4	54,3	7,20	65,84	562,9	29,22	PHC 36S-2...	
40S-2	200-2	63,500	39,68	37,85	19,85	158,8	60,3	8,00	71,55	695,0	32,24	PHC 40S-2...	
16S-3	80-3	25,400	15,88	15,75	7,92	96,1	24,1	3,25	29,29	166,8	7,89	PHC 16S-3...	
20S-3	100-3	31,750	19,05	18,90	9,53	116,3	30,1	4,00	35,76	260,6	11,77	PHC 20S-3...	
24S-3	120-3	38,100	22,23	25,22	11,10	145,2	36,2	4,80	45,44	375,3	17,53	PHC 24S-3...	
28S-3	140-3	44,450	25,40	25,22	12,70	156,8	42,2	5,60	48,87	510,8	22,20	PHC 28S-3...	
32S-3	160-3	50,800	28,58	31,55	14,27	186,6	48,2	6,40	58,55	667,2	30,02	PHC 32S-3...	
36S-3	180-3	57,150	35,71	35,48	17,46	210,2	54,3	7,20	65,84	844,4	38,22	PHC 36S-3...	
40S-3	200-3	63,500	39,68	37,85	19,85	230,4	60,3	8,00	71,55	1042,5	49,03	PHC 40S-3...	
16S-4	80-4	25,400	-	15,75	7,92	122,9	24,1	3,25	29,29	222,4	10,24	PHC 16S-4...	
20S-4	100-4	31,750	19,05	18,90	9,53	151,5	30,1	4,00	35,76	347,5	15,39	PHC 20S-4...	
24S-4	120-4	38,100	22,23	25,22	11,10	190,6	36,2	4,80	45,44	500,4	22,19	PHC 24S-4...	
28S-4	140-4	44,450	25,40	25,22	12,70	205,7	42,2	5,60	48,87	681,1	29,63	PHC 28S-4...	
32S-4	160-4	50,800	28,58	31,55	14,27	245,2	48,2	6,40	58,55	889,6	39,94	PHC 32S-4...	
40S-4	200-4	63,500	39,68	37,85	19,85	302,0	60,3	8,00	71,55	1390,0	63,60	PHC 40S-4...	
16S-5	80-5	25,400	-	15,75	7,92	152,2	24,1	3,25	29,29	278,0	12,79	PHC 16S-5...	
20S-5	100-5	31,750	19,05	18,90	9,53	187,8	30,1	4,00	35,76	434,4	19,22	PHC 20S-5...	
24S-5	120-5	38,100	22,23	25,22	11,10	236,1	36,2	4,80	45,44	625,5	27,71	PHC 24S-5...	
16S-6	80-6	25,400	15,88	15,75	7,92	181,5	24,1	3,25	29,29	333,6	15,34	PHC 16S-6...	
20S-6	100-6	31,750	19,05	18,90	9,53	223,6	30,1	4,00	35,76	521,2	23,05	PHC 20S-6...	
24S-6	120-6	38,100	22,23	25,22	11,10	281,6	36,2	4,80	45,44	750,6	33,24	PHC 24S-6...	
28S-6	140-6	44,450	25,40	25,22	12,70	303,4	42,2	5,60	48,87	1021,6	44,38	PHC 28S-6...	
32S-6	160-6	50,800	28,58	31,55	14,27	362,3	48,2	6,40	58,55	1334,4	59,83	PHC 32S-6...	
40S-6	200-6	63,500	39,68	37,85	19,85	445,0	60,3	8,00	71,55	2085,0	95,23	PHC 40S-6...	
16S-8	80-8	25,400	15,88	15,75	7,92	240,1	24,1	3,25	29,29	444,8	20,44	PHC 16S-8...	
20S-8	100-8	31,750	19,05	18,90	9,53	295,1	30,1	4,00	35,76	695,0	30,71	PHC 20S-8...	
24S-8	120-8	38,100	22,23	25,22	11,10	372,4	36,2	4,80	45,44	1000,8	44,28	PHC 24S-8...	

Standard lengths are 10 ft. To complete designation, add chain length. For example, a 10 ft. box of 40S-6 is PHC 40S-6X10FT. For links, add "C/L" for "connecting" and "O/L" for "offset" to the designation.

# SKF Leaf Chains

SKF Leaf Chains are designed for high load, slow speed tension linkage applications. Often, they are specified for reciprocating motion lifting devices such as forklifts or as counterweight chains for elevators or telescoping equipment, e.g. cranes. The chains are typically supplied in a specific length and connected to a clevis at each end. The clevis may accommodate “male” ends (inside links) or “female” ends (outside links), as required. SKF Leaf Chains are available in series: AL, BL, LL, FL, 12XX, 15XX, 19XX and 25XX. The AL and BL series are based on American chain standards, while the LL series is based on British chain standards. BL series leaf chains are made according to the ASME/ANSI B29.8 American standard. LL series leaf chains are made in accordance with the ISO 606 international standard. A chain with an even number of pitches has one male and one female end. A chain with an odd number of pitches have either two male or two female ends.

## Application

The applications for these chains include counterweight chain for masts, elevator and oven doors, forklift truck masts, spinning frames and any other lifting or balancing application.



*SKF Leaf Chains used for lifting in a forklift mast*



## SKF Leaf Chains - ANSI BL422-BL888

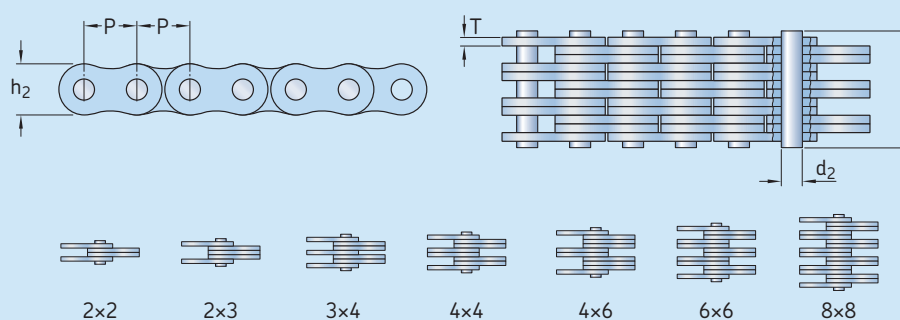

ANSI Chain number	BS/ISO Chain number	Dimensions		Plate height	Plate thickness	Pin diameter	Pin length	Ultimate tensile strength	Average tensile strength	Weight per meter	Designation
		Pitch	Plate lacing								
		P		$h_2$ max	T max	$d_2$ max	L max	Q min	$Q_0$	q	
		mm						kN		kg/m	
BL422	LH0822	12,7	2 × 2	12,07	2,08	5,09	11,05	22,2	27,6	0,64	PHC BL422...
BL423	LH0823		2 × 3				13,16	22,2	27,6	0,80	PHC BL423...
BL434	LH0834		3 × 4				17,40	33,4	41,4	1,12	PHC BL434...
BL444	LH0844		4 × 4				19,51	44,5	56,0	1,28	PHC BL444...
BL446	LH0846		4 × 6				23,75	44,5	56,0	1,60	PHC BL446...
BL466	LH0866		6 × 6				27,99	66,7	81,7	1,92	PHC BL466...
BL488	LH0888		8 × 8				36,45	89,0	109,4	2,56	PHC BL488...
BL522	LH1022	15,875	2 × 2	15,09	2,44	5,96	12,90	33,4	43,1	0,88	PHC BL522...
BL523	LH1023		2 × 3				15,37	33,4	43,1	1,10	PHC BL523...
BL534	LH1034		3 × 4				20,32	48,9	65,6	1,50	PHC BL534...
BL544	LH1044		4 × 4				22,78	66,7	84,5	1,80	PHC BL544...
BL546	LH1046		4 × 6				27,74	66,7	84,5	2,20	PHC BL546...
BL566	LH1066		6 × 6				32,69	100,1	125,1	2,65	PHC BL566...
BL588	LH1088		8 × 8				42,57	133,4	169,5	3,50	PHC BL588...
BL622	LH1222	19,05	2 × 2	18,11	3,30	7,94	17,37	48,9	63,6	1,45	PHC BL622...
BL623	LH1223		2 × 3				20,73	48,9	63,6	1,80	PHC BL623...
BL634	LH1234		3 × 4				27,43	75,6	102,8	2,50	PHC BL634...
BL644	LH1244		4 × 4				30,78	97,9	120,9	2,90	PHC BL644...
BL646	LH1246		4 × 6				37,49	97,9	120,9	3,60	PHC BL646...
BL666	LH1266		6 × 6				44,20	146,8	190,8	4,30	PHC BL666...
BL688	LH1288		8 × 8				57,61	195,7	238,8	5,80	PHC BL688...
BL822	LH1622	25,4	2 × 2	24,13	4,09	9,54	21,34	84,5	108,2	2,20	PHC BL822...
BL823	LH1623		2 × 3				25,48	84,5	108,2	2,70	PHC BL823...
BL834	LH1634		3 × 4				33,76	129,0	170,0	3,80	PHC BL834...
BL844	LH1644		4 × 4				37,90	169,0	214,6	4,30	PHC BL844...
BL846	LH1646		4 × 6				46,18	169,0	214,6	5,40	PHC BL846...
BL866	LH1666		6 × 6				54,46	253,6	324,5	6,50	PHC BL866...
BL888	LH1688		8 × 8				71,02	338,1	432,7	8,60	PHC BL888...

Standard lengths are 10 ft. and 5 m. To complete designation, add chain length. For example, a 10 ft. box of BL422 is PHC BL422X10FT.

## SKF Leaf Chains – ANSI BL1022-BL2088

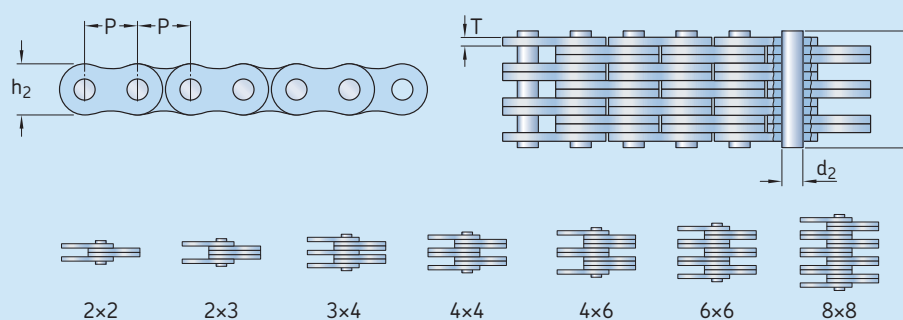

ANSI Chain number	BS/ISO Chain number	Dimensions		Plate height	Plate thickness	Pin diameter	Pin length	Ultimate tensile strength	Average tensile strength	Weight per meter	Designation
		Pitch	Plate lacing								
		P		$h_2$ max	T max	$d_2$ max	L max	Q min	$Q_0$	q	
		mm	–					kN		kg/m	–
BL1022	LH2022	31,75	2 × 2	30,18	4,9	11,11	25,37	115,6	150,8	3,40	PHC BL1022...
BL1023	LH2023		2 × 3				30,33	115,6	150,8	4,30	PHC BL1023...
BL1034	LH2034		3 × 4				40,23	182,4	231,6	6,00	PHC BL1034...
BL1044	LH2044		4 × 4				45,19	231,3	291,4	6,90	PHC BL1044...
BL1046	LH2046		4 × 6				55,09	231,3	291,4	8,60	PHC BL1046...
BL1066	LH2066		6 × 6				65,00	347,0	430,3	10,30	PHC BL1066...
BL1088	LH2088		8 × 8				84,81	462,6	555,1	13,80	PHC BL1088...
BL1222	LH2422	38,1	2 × 2	36,20	5,77	12,71	29,62	151,2	192,0	4,6	PHC BL1222...
BL1223	LH2423		2 × 3				35,43	151,2	192,0	5,8	PHC BL1223...
BL1234	LH2434		3 × 4				47,07	244,6	315,9	8,1	PHC BL1234...
BL1244	LH2444		4 × 4				52,88	302,5	381,1	9,3	PHC BL1244...
BL1246	LH2446		4 × 6				64,52	302,5	381,1	11,6	PHC BL1246...
BL1266	LH2466		6 × 6				76,15	453,7	543,6	13,9	PHC BL1266...
BL1288	LH2488		8 × 8				99,42	605,0	726,0	18,6	PHC BL1288...
BL1422	LH2822	44,45	2 × 2	42,24	6,55	14,29	33,55	191,3	225,7	6,1	PHC BL1422...
BL1423	LH2823		2 × 3				40,16	191,3	225,7	7,6	PHC BL1423...
BL1434	LH2834		3 × 4				53,37	315,8	372,6	10,6	PHC BL1434...
BL1444	LH2844		4 × 4				59,97	382,6	451,2	12,2	PHC BL1444...
BL1446	LH2846		4 × 6				73,18	382,6	451,2	15,2	PHC BL1446...
BL1466	LH2866		6 × 6				86,39	578,3	682,4	18,2	PHC BL1466...
BL1488	LH2888		8 × 8				112,80	765,1	902,8	24,3	PHC BL1488...
BL1622	LH3222	50,8	2 × 2	48,26	7,52	17,46	39,01	289,1	341,1	8,0	PHC BL1622...
BL1623	LH3223		2 × 3				46,58	289,1	341,1	10,0	PHC BL1623...
BL1634	LH3234		3 × 4				61,72	440,4	519,6	14,0	PHC BL1634...
BL1644	LH3244		4 × 4				69,29	573,8	680,4	16,0	PHC BL1644...
BL1646	LH3246		4 × 6				84,43	578,3	680,4	20,0	PHC BL1646...
BL1666	LH3266		6 × 6				99,57	857,4	1000,7	24,0	PHC BL1666...
BL1688	LH3288		8 × 8				129,84	1156,5	1364,6	32,0	PHC BL1688...
BL2022	LH4022	63,5	2 × 2	60,33	9,91	23,81	51,74	433,7	511,7	15,8	PHC BL2022...
BL2023	LH4023		2 × 3				61,70	433,7	511,7	19,8	PHC BL2023...
BL2034	LH4034		3 × 4				81,61	649,4	766,2	27,7	PHC BL2034...
BL2044	LH4044		4 × 4				91,57	867,4	1023,5	31,6	PHC BL2044...
BL2046	LH4046		4 × 6				111,48	867,4	1023,5	39,5	PHC BL2046...
BL2066	LH4066		6 × 6				131,39	1301,1	1535,2	47,4	PHC BL2066...
BL2088	LH4088		8 × 8				171,22	1734,8	2046,5	63,2	PHC BL2088...

Standard lengths are 10 ft. and 5 m. To complete designation, add chain length. For example, a 10 ft. box of BL1022 is PHC BL1022X10FT.

## SKF Leaf Chains – BS/ISO LL0822-LL4888

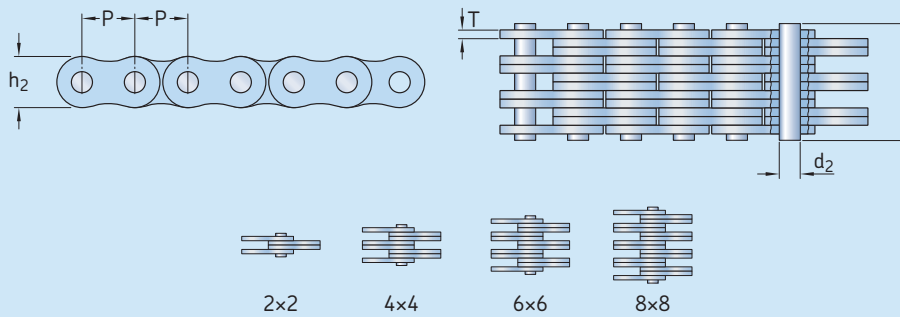

BS/ISO Chain number	Dimensions		Plate height	Plate thickness	Pin diameter	Pin length	Ultimate tensile strength	Average tensile strength	Weight per meter	Designation
	Pitch	Plate lacing								
–	P	–	$h_2$ max	T max	$d_2$ max	L max	Q min	$Q_0$	q	–
–	mm	–	–	–	–	–	kN	–	kg/m	–
LL0822	12,7	2 × 2	10,6	1,6	4,45	8,9	18,2	20,4	0,42	PHC LL0822...
LL0844		4 × 4				15,6	36,4	40,7	0,84	PHC LL0844...
LL0866		6 × 6				22,0	54,6	60	1,24	PHC LL0866...
LL0888		8 × 8				28,5	72,8	80	1,64	PHC LL0888...
LL1022	15,875	2 × 2	13,7	1,6	5,08	9,2	22,7	25,5	0,54	PHC LL1022...
LL1044		4 × 4				15,8	45,4	51	1,06	PHC LL1044...
LL1066		6 × 6				22,1	68,1	76,3	1,57	PHC LL1066...
LL1088		8 × 8				28,8	90,8	101,9	2,1	PHC LL1088...
LL1222	19,05	2 × 2	16	1,85	5,72	10,4	29,5	33,2	0,73	PHC LL1222...
LL1244		4 × 4				17,9	59,0	66,4	1,44	PHC LL1244...
LL1266		6 × 6				25,4	88,5	99,7	2,15	PHC LL1266...
LL1288		8 × 8				32,9	118,0	132,9	2,84	PHC LL1288...
LL1622	25,4	2 × 2	21	3,1	8,28	17,2	58,0	66,7	1,52	PHC LL1622...
LL1644		4 × 4				29,6	116,0	140	2,9	PHC LL1644...
LL1666		6 × 6				42,4	174,0	208,8	4,3	PHC LL1666...
LL1688		8 × 8				54,9	232,0	278	5,71	PHC LL1688...
LL2022	31,75	2 × 2	26,4	3,5	10,19	20,1	95,0	109,2	2,33	PHC LL2022...
LL2044		4 × 4				33,8	190,0	218,5	4,4	PHC LL2044...
LL2066		6 × 6				50,1	285,0	324,6	6,79	PHC LL2066...
LL2088		8 × 8				64,0	380,0	435,1	8,9	PHC LL2088...
LL2422	38,1	2 × 2	33,4	5	14,63	28,4	170,0	195,5	4,47	PHC LL2422...
LL2444		4 × 4				46,3	340,0	380,8	8,22	PHC LL2444...
LL2466		6 × 6				66,4	510,0	571,2	12,22	PHC LL2466...
LL2488		8 × 8				86,6	680,0	775,2	16,3	PHC LL2488...
LL2822	44,45	2 × 2	37,08	6	15,9	32,2	200,0	224	5,1	PHC LL2822...
LL2844		4 × 4				56,4	400,0	448	9,9	PHC LL2844...
LL2866		6 × 6				80,8	600,0	672	14,6	PHC LL2866...
LL2888		8 × 8				105,2	800,0	896	19,4	PHC LL2888...
LL3222	50,8	2 × 2	42	6,4	17,81	34,8	260,0	291,2	6,2	PHC LL3222...
LL3244		4 × 4				60,6	520,0	582,4	12,3	PHC LL3244...
LL3266		6 × 6				86,4	780,0	873,6	18,3	PHC LL3266...
LL3288		8 × 8				112,2	1040,0	1176	24	PHC LL3288...
LL4022	63,5	2 × 2	52,76	8	22,89	42,2	360,0	403,2	10,3	PHC LL4022...
LL4044		4 × 4				74,4	780,0	873,6	20	PHC LL4044...
LL4066		6 × 6				106,5	1080,0	1209,6	30	PHC LL4066...
LL4088		8 × 8				140,0	1440,0	1747,2	39,1	PHC LL4088...
LL4822	76,2	2 × 2	63,88	10	29,24	54,6	560,0	627,2	18,5	PHC LL4822...
LL4844		4 × 4				92,6	1120,0	1554,4	35,7	PHC LL4844...
LL4866		6 × 6				133,4	1680,0	1880	53	PHC LL4866...
LL4888		8 × 8				174,2	2240,0	2508,8	70,4	PHC LL4888...

Standard lengths are 10 ft. and 5 m. To complete designation, add chain length. For example, a 10 ft. box of LL1022 is PHC LL1022X10FT.

## SKF Leaf Chains – ANSI AL322-AL1688

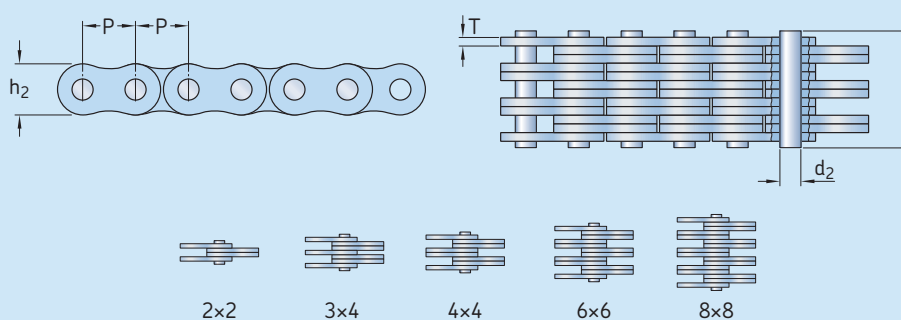

ANSI Chain number	Dimensions		Plate height	Plate thickness	Pin diameter	Pin length	Ultimate tensile strength	Average tensile strength	Weight per meter	Designation
	Pitch	Plate lacing								
	P		$h_2$ max	T max	$d_2$ max	L max	Q min	$Q_0$	q	
	mm	–					kN		kg/m	–
AL322	9,525	2 × 2	7,7	1,3	3,58	6,80	9,0	10,2	0,23	PHC AL322...
AL344		4 × 4				11,60	18,0	20,0	0,46	PHC AL344...
AL422	12,7	2 × 2	10,4	1,5	3,96	8,30	14,1	16,9	0,39	PHC AL422...
AL444		4 × 4				14,40	28,2	35,2	0,74	PHC AL444...
AL466		6 × 6				20,50	42,3	52,7	1,13	PHC AL466...
AL522	15,875	2 × 2	12,8	2,03	5,08	11,05	22,0	27,5	0,64	PHC AL522...
AL534		3 × 4				17,00	33,0	46,0	1,10	PHC AL534...
AL544		4 × 4				19,40	44,0	55,0	1,25	PHC AL544...
AL566		6 × 6				27,50	66,0	82,5	1,79	PHC AL566...
AL622	19,05	2 × 2	15,6	2,42	5,94	13,00	37,0	44,4	0,86	PHC AL622...
AL644		4 × 4				22,70	63,7	78,8	1,76	PHC AL644...
AL666		6 × 6				32,20	100,1	118,6	2,60	PHC AL666...
AL688		8 × 8				42,20	133,4	156,6	3,49	PHC AL688...
AL822	25,4	2 × 2	20,5	3,25	7,92	16,00	56,7	68,6	1,54	PHC AL822...
AL844		4 × 4				29,40	113,4	135,6	3,00	PHC AL844...
AL866		6 × 6				44,20	170,0	202,3	4,46	PHC AL866...
AL1022	31,75	2 × 2	25,6	4	9,53	19,60	88,5	107,1	2,37	PHC AL1022...
AL1044		4 × 4				36,40	177,0	203,6	4,68	PHC AL1044...
AL1066		6 × 6				52,30	265,0	315,3	7,20	PHC AL1066...
AL1088		8 × 8				68,50	354,0	421,2	9,94	PHC AL1088...
AL1222	38,1	2 × 2	30,5	4,8	11,1	24,30	127,0	151,1	3,65	PHC AL1222...
AL1244		4 × 4				43,80	254,0	299,7	7,05	PHC AL1244...
AL1266		6 × 6				63,20	381,0	426,3	10,50	PHC AL1266...
AL1288		8 × 8				82,60	508,0	568,4	14,03	PHC AL1288...
AL1444	44,45	4 × 4	36,4	5,6	12,64	51,30	372,7	413,6	10,34	PHC AL1444...
AL1466		6 × 6				74,56	559,0	620,4	15,16	PHC AL1466...
AL1644	50,8	4 × 4	41,6	6,4	14,21	58,00	471,0	522,8	12,98	PHC AL1644...
AL1666		6 × 6				83,80	706,0	783,6	19,76	PHC AL1666...
AL1688		8 × 8				109,50	942,0	1045,5	25,47	PHC AL1688...

Standard lengths are 10 ft. and 5 m. To complete designation, add chain length. For example, a 10 ft. box of AL322 is PHC AL322X10FT.

## SKF Leaf Chains – FL, F19V, FLC

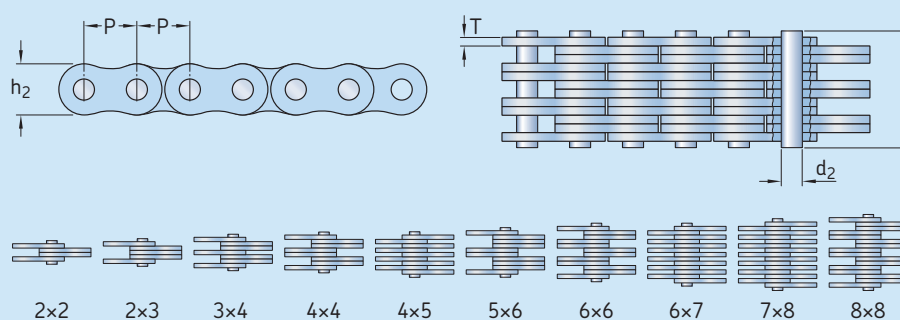

Chain number	Dimensions			Plate thickness	Pin diameter	Pin length	Ultimate tensile strength	Average tensile strength	Weight per meter	Designation
	Pitch	Plate lacing	Plate height							
	P		$h_2$ max	T max	$d_2$ max	L max	Q min	$Q_0$	q	
	mm	–					kN		kg/m	–
FL644	5,940	4 × 4	4,7	0,60	1,85	6,6	6,50	7,8	0,13	PHC FL644...
FL666	5,940	6 × 6	4,7	0,60	1,85	9,3	9,75	11,8	0,20	PHC FL666...
FL688	5,940	8 × 8	4,7	0,60	1,85	12,0	13,00	15,6	0,25	PHC FL688...
FL844	8,000	4 × 4	6,9	0,73	2,31	7,9	10,00	12,1	0,25	PHC FL844...
FL944	9,525	4 × 4	8,7	1,04	3,28	10,4	21,00	24,7	0,43	PHC FL944...
FL966	9,525	6 × 6	8,7	1,00	3,28	14,9	31,00	36,8	0,65	PHC FL966...
F122	12,700	2 × 2	8,2	1,00	3,58	7,0	11,43	13,6	0,19	PHC F122...
F1223	12,700	2 × 3	10,2	2,03	4,45	12,8	20,00	23,8	0,61	PHC F1223...
FL1244	12,700	4 × 4	10,2	1,70	4,45	16,7	44,00	52,3	0,83	PHC FL1244...
F19V-44	19,050	4 × 4	15,2	2,42	6,50	22,4	71,00	84,3	1,73	PHC F19V-44...
F19V-66	19,050	6 × 6	15,2	2,42	6,50	32,3	106,00	125,9	2,57	PHC F19V-66...
FLC534	15,875	3 × 4	12,7	1,85	5,08	15,3	40,40	44,4	0,99	PHC FLC534...
FLC545	15,875	4 × 5	12,7	1,85	5,08	19,2	54,30	59,7	1,27	PHC FLC545...
FLC556	15,875	5 × 6	12,7	1,85	5,08	22,7	67,60	74,3	1,54	PHC FLC556...
FLC1056	31,750	5 × 6	25,4	3,25	9,53	40,6	137,90	151,0	5,44	PHC FLC1056...
FLC1067	31,750	6 × 7	25,4	3,25	9,53	47,2	165,40	181,9	6,42	PHC FLC1067...
FLC1078	31,750	7 × 8	25,4	3,25	9,53	53,8	193,00	212,0	7,40	PHC FLC1078...

Standard lengths are 10 ft. and 5 m. To complete designation, add chain length. For example, a 10 ft. box of AL322 is PHCAL322X10FT.

## SKF Leaf Chains – 12XX, 15XX, 19XX, 25XX

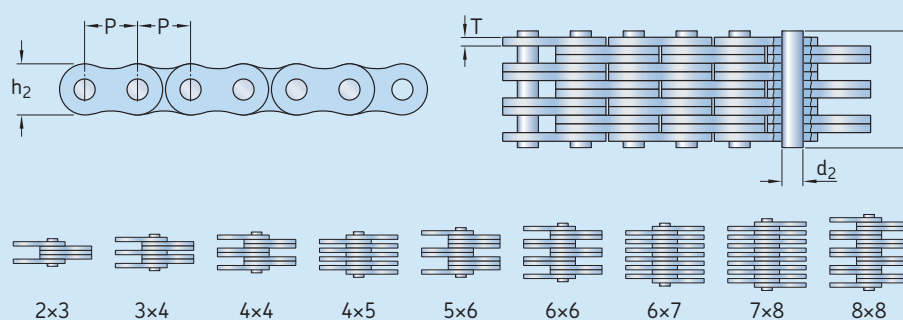

Chain number	Dimensions						Chain length over 100 pitches ( $\pm 0,25\%$ )	Ultimate tensile strength	Weight per meter	Designation
	Pitch	Plate lacing	Plate height	Plate thickness	Pin diameter	Pin length				
	P		$h_2$ max	T max	$d_2$ max	L max		Q min	q	
	mm							kN	kg/m	
1234	12,7	3 × 4	10,6	1,7	4,45	14,2	1262	31,0	0,75	PHC 1234...
1256		5 × 6				21,1		53,0	1,17	PHC 1256...
1288		8 × 8				29,9		85,0	1,70	PHC 1288...
1523	15,875	2 × 3	12,7	1,94	5,08	12,1	1580	29,0	0,75	PHC 1523...
1534		3 × 4				16,0		46,0	1,04	PHC 1534...
1544		4 × 4				18,1		58,0	1,18	PHC 1544...
1545		4 × 6				20,3		58,0	1,33	PHC 1545...
1556		5 × 6				24,0		72,0	1,63	PHC 1556...
1566		6 × 6				26,2		87,0	1,77	PHC 1566...
1567		6 × 7				28,0		90,0	1,91	PHC 1567...
1578		7 × 8				32,5		101,0	2,20	PHC 1578...
1588		8 × 8				34,0		115,0	2,34	PHC 1588...
1944	19,05	4 × 4	15,0	2,29	5,72	21,3	1891	73,0	1,58	PHC 1944...
1966		6 × 6				30,7		110,0	2,37	PHC 1966...
1988		8 × 8				40,0		140,0	3,13	PHC 1988...
2523	25,4	2 × 3	20,2	3,06	8,28	18,8	2532	72,0	1,83	PHC 2523...
2534		3 × 4				25,3		108,0	2,55	PHC 2534...
2545		4 × 5				31,6		144,0	3,26	PHC 2545...
2556		5 × 6				37,2		180,0	3,96	PHC 2556...
2567		6 × 7				43,8		216,0	4,68	PHC 2567...
2578		7 × 8				50,0		252,0	5,39	PHC 2578...
2588		8 × 8				52,8		290,0	5,77	PHC 2588...

Standard lengths are 10 ft. and 5 m. To complete designation, add chain length. For example, a 10 ft. box OF1234 is PHC 1234X10FT.

# Chain chemical resistance comparison

The selection of the correct chain type for the application also requires an assessment of the material type the chain is made from, or plated, and how this will react with the expected environment.

The information in the chart is given as a guideline only, not a guarantee for the performance of the materials, the variables for each operating condition, such as heat and concentration, can substantially change the results.



Chain chemical resistance comparison						
Substance	Concentration	Temperature	Carbon steel	Stainless steel grade		
				304	316	600
-	-	°C	-			
Acetic acid	5-10%	20	●	▲	▲	▲
Acetone	-	20	●	▲	▲	▲
Alcohol	-	-	▲	▲	▲	▲
Ammonia water	-	-	▽	▲	▲	▲
Ammonia nitrate	Saturated	Boiling	●	▲	▲	▲
Beer	-	20	▽	▲	▲	▲
Benzene	-	20	▲	▲	▲	▲
Boric acid	50%	Boiling	●	▲	▲	▲
Butyric acid	-	20	▲	▲	▲	▲
Calcium chloride	Saturated	20	●	▽	▲	●
Calcium hydroxide	20%	Boiling	●	▲	▲	▲
Carbolic acid	-	-	▽	▲	▲	▲
Carbon tetrachloride (dry)	-	20	▽	▲	▲	▲
Chlorinated water	-	-	●	●	▲	●
Chlorine gas (dry)	-	20	●	▽	▽	●
Chlorine gas (moist)	-	20	●	●	▽	●
Chromic acid	5%	20	●	▲	▲	▲
Chocolate	-	-	▽	▲	▲	▲
Citric acid	50%	20	●	▲	▲	▲
Coffee	-	Boiling	●	▲	▲	▲
Ferric acid	50%	20	●	▲	▲	▲
Ferric chloride	5%	20	●	▽	▽	▽
Formalin (formaldehyde)	40%	20	▲	▲	▲	▲
Formic acid	50%	20	●	▲	▲	▲
Fruit juice	-	20	●	▲	▲	▽
Gasoline	-	20	▲	▲	▲	▲
Grape husk	-	-	●	●	▽	●
Glycerol	-	20	●	▲	▲	▲
Honey/molasses	-	-	●	▲	▲	▲
Hydrochloric acid	2%	20	●	●	●	●
Hydrogen peroxide	30%	20	●	▲	▲	▲
Hydrogen sulphide (dry)	-	-	●	▲	▲	▲
Hydrogen sulphide (moist)	-	-	●	●	●	●
Iodine	-	-	●	●	●	●
Lactic acid	10%	20	●	▲	▲	▽
Linseed oil	100%	20	▲	▲	▲	▽

Legend for Symbols ▲ Highly Corrosion Resistant ● Not Corrosion Resistant ▽ Marginal Corrosion Resistant

### Chain chemical resistance comparison

Substance	Concentration	Temperature	Carbon steel	Stainless steel grade		
				304	316	600
–	–	°C	–			
Mayonnaise	–	20	●	▲	▲	▽
Milk	–	20	▲	▲	▲	▲
Nitric acid	5%	20	●	▲	▲	▽
Nitric acid	65%	20	●	▲	▲	▽
Nitric acid	65%	Boiling	●	▽	▽	●
Oil	–	20	▲	▲	▲	▲
Oil (vegetable, mineral)	–	20	▲	▲	▲	▲
Oxalic acid	10%	20	●	▲	▲	▽
Paraffin	–	20	▲	▲	▲	▲
Petroleum	–	20	▲	▲	▲	▲
Phosphoric acid	5%	20	●	▲	▲	▽
Phosphoric acid	10%	20	●	▽	▽	▽
Potassium	Saturated	20	●	▲	▲	▽
Potassium bichromate	10%	20	●	▲	▲	▲
Potassium chloride	Saturated	20	●	▲	▲	▲
Potassium hydroxide	20%	20	●	▲	▲	▲
Potassium nitrate	25%	20	●	▲	▲	▲
Potassium nitrate	25%	Boiling	●	▲	▲	●
Seawater	–	20	●	▽	▽	●
Soap + water solution	–	20	▽	▲	▲	▲
Sodium carbonate	Saturated	Boiling	●	▲	▲	▲
Sodium chloride	5%	20	●	▲	▲	▽
Sodium cyanide	–	20	●	▲	▲	●
Sodium hydrocarbonate	–	20	●	▲	▲	▲
Sodium hydroxide	25%	20	●	▲	▲	▲
Sodium hyperchlorite	10%	20	●	●	▲	●
Sodium perchlorate	10%	Boiling	●	▲	▲	●
Soft drink	–	20	▽	▲	▲	▲
Stearic acid	100%	Boiling	●	●	▽	●
Sugar solution	–	20	●	▲	▲	▲
Spirits	–	20	▲	▲	▲	▲
Sulphuric acid (sulfuric)	5%	20	●	●	▲	●
Sulphuric acid (sulfuric)	40%	20	●	●	●	●
Toulene	–	20	▽	▽	▽	▽
Turpentine	–	30	▲	▲	▲	▲
Vegetable juice	–	20	▽	▲	▲	▲
Vinegar	–	20	●	▽	▲	▽
Water	–	–	●	▲	▲	▲
Whiskey	–	20	●	▲	▲	▲
Wine	–	20	▲	▲	▲	▲
Zinc chloride	50%	20	●	▽	▽	●
Zinc sulfate	25%	20	●	▲	▲	●

Legend for Symbols ▲ Highly Corrosion Resistant ● Not Corrosion Resistant ▽ Marginal Corrosion Resistant



The corrosion resistance of plated carbon steel chains is better than non plated carbon steel chains, but not as good as the stainless steel options.

Some indicative comparisons for corrosion resistance is given below, along with relative costs (to that of standard chains)

Plating / Coating	Conditions / Environment	Relative cost (to Std chain)	Typical corrosion resistance to		Typical effect on $Q_{min}^{2)}$
			Rain	Seawater	
–	–	°C	–		
<b>Zinc plated (ZP)<sup>1)</sup></b>	Better anti-corrosion than nickel plate, not environmental plating process	1.25–1.30	▲	▽	0,85
<b>Nickel plated (NP)<sup>1)</sup></b>	Outdoor use plated chain, mildly corrosive resistant	1.15–1.20	▽	●	0,95
<b>Dacrotized (DR)<sup>1)</sup></b>	Best treatment for anti-corrosion of carbon steel chains, next to Stainless steel	1.60–1.70	▲	▲	1,00

Legend for Symbols   ▲ Highly Corrosion Resistant   ● Not Corrosion Resistant   ▽ Marginal Corrosion Resistant

<sup>1)</sup> The plating types used in all the above processes can be prone to flaking or dusting when being used in certain conditions. They can therefore not be used in applications where the chains come into direct contact with food, as there is a very small chance of product contamination.  
<sup>2)</sup> Where standard carbon steel chains are plated, the process may have an effect on the chains performance, and as a result, the UTS ( $Q_{min}$ ) and working load may have to be adjusted by the factors indicated. There is no effect on capacity when using a "dacrotised" chain.

The plated chains are all plated before assembly, to ensure full coverage of each part.

NOTE: The plating types used in all the above processes can be prone to flaking or dusting when being used in certain conditions. They can therefore not be used in applications where the chains come into direct contact with food, as there is a very small chance of product contamination.



# Useful formulae for power transmission

## 1 Power (kW)

### 1.1 Mechanical Power ( $kW_M$ )

$$kW_M = \frac{M_T \times \text{rpm}}{9\,550} \quad (\text{kW})$$

Where

$M_T$  Torque (moment) [Nm]  
rpm revolutions per minute [ $\text{min}^{-1}$ ]

### 1.2 Electrical Power ( $kW_E$ ):-

$$kW_E = \frac{\sqrt{3} \times V \times I \times \text{Cos}\phi}{1,000} \quad (\text{kW})$$

Where

V Voltage  
(Typically 415 V for 3 ph.; 240 V for single ph.)  
I Current (amps)  
cos  $\phi$  Power Factor (typically 0.82–0.95. Ref motor catalogue)  
 $\sqrt{3}$  1.73 (A constant for 3 phase machines...415 V. (Ignore for single phase machines... typically 240 V AC)

Note: To calculate the output kW, multiply the  $kW_E$  by the overall mechanical efficiency ( $O\xi m$ ).

## 2 Torque (or Moment) ( $M_T$ )

### 2.1 Basic Formulae:-

$$M_T = F \times r \quad (\text{Nm})$$

Where

F Force (Newtons)  
r radius of element (metres)

### 2.2 Power and speed known

$$M_T = \frac{\text{kW} \times 60 \times 10^3}{2 \times \pi \times \text{rpm}} \quad (\text{Nm})$$

Where

$M_T$  Torque (Moment) [Nm]  
kW Kilowatt [kW]  
rpm revolutions per minute [ $\text{min}^{-1}$ ]  
9 550 is a constant, derived from:  $(60 \times 10^3) / 2\pi$

### 2.3 Alternatively, this may be reduced to

$$M_T = \frac{\text{kW} \times 9950}{\text{rpm}} \quad (\text{Nm})$$

## 3 Overhung loads (Radial Force) ( $F_R$ )

### 3.1 Radial Force [ $F_R$ ]

$$F_R = \frac{2 \times \text{kW} \times 9950}{d \text{ rpm}} \quad (\text{N})$$

Where

kW Power [kW]  
d Pitch Circle Diameter - pcd - [m]  
rpm revolutions per minute [ $\text{min}^{-1}$ ]

### 3.2 Overhung Loads [ $F_R$ ]:

$$F_R = \frac{2 \times \text{kW} \times 9950 \times K}{d \times \text{rpm}} \quad (\text{N})$$

Where

$K_1$  A Constant, dependent on the driving element, typically

For Chain Pinions

(>19T) = 1.00  
(14T-18T) = 1.25  
(<13T) = 1.40

Gears

(>17T) = 1.15  
(<17T) = 1.30

V-Pulleys

= 1.50

Flat Belts

= 2.50 – 3.00

(dependent on type / construction or material)

#### 4 Velocity (Linear Motion) (m/s)

##### 4.1 Velocity (v)

$$v = \frac{d \times \pi \times \text{rpm}}{60 \times 10^3} \quad (\text{m/s})$$

Where

v velocity in metres per second [m/s]

d pitch circle diameter - pcd - [mm].

(Note: If the pitch diameter is in metres, ignore the  $\times 10^3$  denominator).

##### 4.2 For Chain Drives ( $v_1$ )

$$v_1 = \frac{p \times z \times \text{rpm}}{60 \times 10^3} \quad (\text{m/s})$$

Where

p chain pitch (mm)

z No of teeth of sprocket

##### 4.3 Angular Acceleration (a) may be derived from the above

$$\alpha = \frac{(v_1 - v_2)}{t} \times 2 \times \pi \quad (\text{rad/sec}^2)$$

Where

$\alpha$  Angular acceleration (radians per second<sup>2</sup>)

$v_1, v_2$ , Velocities 1 and 2 respectively (m/s)

T time period between the velocities  $v_1$  and  $v_2$  (sec)

#### 5 Sprocket (or Chain Wheel) pitch diameters ( $\varnothing_p$ )

##### 5.1 Pitch Diameters ( $\varnothing_p$ )

$$\varnothing_p = \left[ \sin \frac{180}{z} \right]^{-1} \quad (\text{mm})$$

Where

$\varnothing_p$  Pitch diameter [mm]

z No of teeth of sprocket

p Chain Pitch [mm]

Sin Trig. Function

#### 6 Ratios (i)

$$i = \frac{N_1}{N_2} = \frac{M_2}{M_1} = \frac{D_1}{D_2} = \frac{Z_2}{Z_1} \quad (:1) \text{ (no unit!)}$$

Where

$N_1, N_2$  input and output speeds respectively [rpm]

$M_1, M_2$  input and output torque (moment) respectively [Nm]

$\varnothing_1, \varnothing_2$  DriveR & DriveN pulleys (mm or inch)

$Z_1, Z_2$  Number of Sprocket Teeth on DriveR and DriveN

#### 7 Factors and efficiencies

##### 7.1 Gearbox efficiencies ( $\xi$ ) (Typical only. Refer to manufacturers' tables for actual values)

###### 7.1.1 Helical units single reduction 0.97

Double reduction 0.94

Triple reduction 0.91

###### 7.1.2 Spur units single reduction 0.95

Double reduction 0.91

Triple reduction 0.88

###### 7.1.3 Worm units For small units (centres < 150 mm ...), an approximation of the mechanical efficiency can be made by means of subtracting the ratio from 100. (e.g. For a 40:1 ratio unit, the $\alpha\xi m$ is approx. 60%...

The larger the worm box centres, the more efficient (relatively) the unit!!!

##### 7.2 V, Multi-rib and Synchronous Belts

###### 7.2.1 Standard V-belts...classical jacketed 0.94 – 0.97

###### 7.2.2 Raw-edge type V-belts 0.96 – 0.98

###### 7.2.3 Standard synchronous (Trapezoidal profile – CTB) 0.96 – 0.97

###### 7.2.4 High Performance sync. Belts 0.97 – 0.98 (Curvilinear and modified Curvilinear....)

(The above belt efficiencies are based on new installations, with correctly maintained tensions).

##### 7.3 (More common) Co-efficient of friction ( $\mu$ ) for different materials

Steel on Steel	Static friction (dry)	$\mu = 0.12 - 0.6$
	Sliding friction (dry)	$\mu = 0.08 - 0.5$
	Static friction (greased)	$\mu = 0.12 - 0.35$
	Sliding friction (greased)	$\mu = 0.04 - 0.25$
Wood on Steel	Static friction (dry)	$\mu = 0.45 - 0.75$
	Sliding friction (dry)	$\mu = 0.30 - 0.60$
Wood on Wood	Static friction (dry)	$\mu = 0.40 - 0.75$
	Sliding friction (dry)	$\mu = 0.30 - 0.50$
Polymer on Wood	Static friction (dry)	$\mu = 0.25 - 0.45$
	Sliding friction (dry)	$\mu = 0.25$
Steel on Polymer	Static friction (dry)	$\mu = 0.40 - 0.45$
	Sliding friction (greased)	$\mu = 0.18 - 0.35$

#### 8 Common conversion factors and constants

##### 8.1 Power [kW]

Hp  $\times 0.746$  Kilowatt (kW)

PS  $\times 0.7355$  Kilowatt (kW)

kp m/s  $\times 0.0981$  Kilowatt (kW)

kcal/s  $\times 4.1868$  Kilowatt (kW)

##### 8.2 Torque (Moment) [Nm]

kgf-m  $\times 9.81$  Newton-metre (Nm)

lbf-in  $\times 0.1129$  Newton-metre (Nm)

lbf-ft  $\times 1.36$  Newton-metre (Nm)

**8.3 Force [N]**

Kgf × 9.81	Newton (N)
lbf × 4.45	Newton (N)
Kp × 9.81	Newton (N)

(Kp = kilopond)

**8.4 Pressure and stress (MN/m<sup>2</sup> or N/mm<sup>2</sup>)**

pascal (Pa)	10 <sup>2</sup> N/m <sup>2</sup>
lb/in <sup>2</sup> × 6.895 × 10 <sup>3</sup>	newton/metre <sup>2</sup> (N/m <sup>2</sup> )

**8.5 Velocity [m/s]**

1 m/s	196.86 feet / minute
fpm × 5.0797 × 10 <sup>3</sup>	metres/second (m/s)
miles an hour (mph)	0.447 metres / second (m/s)

**8.6 Capacity flow**

1 litre / sec	0.5886 × 10 <sup>3</sup> ft <sup>3</sup> / min
1 m <sup>3</sup> / s	35.3147 ft <sup>3</sup> /s (cusec)

**8.7 Density**

pound / inch <sup>3</sup>	27.68 gram / centimeter
	2.768 × 10 <sup>4</sup> kilogramme/metre <sup>3</sup>
	(kg/m <sup>3</sup> )
ton/yard <sup>3</sup>	693.6 kilogramme/metre <sup>3</sup> (kg/m <sup>3</sup> )

**8.8 Mass**

pound (lb)	0.4536 kilogramme (kg)
kilogramme	2.205 pounds (lb)
stone	6.35 kilogramme (kg)
ounce (oz)	0.02835 kilogramme (kg)
Ton (short)	0.9072 tonne (metric)

**8.9 Energy**

BTU (British Thermal Unit)	1 055 Joule (J)
	1 055 newton-metre (Nm)
	0.252 kilocalorie
	0.02931 × 10 <sup>3</sup> kilowatt-hour
	(kWh)
	0.393 × 10 <sup>3</sup> horsepower-hour

# SKF Lubrication Systems

SKF can recommend the right oil projection system for specific application needs.

## SKF ChainLube, air assisted oil projection system

Is best suited to lubricate chains where no pitch detection is possible due to fast movement of chain or when pitch is too small (less than 50 mm). Regulated carrier air flow is used to project small amount of lubricant, having viscosity up to 400 cSt with virtually no mist formation around the projection nozzles.

## SKF ChainLube, airless oil projection system

Suitable for accurate lubrication of chains pitch-by-pitch without the need to connect to a compressed air supply. Suitable for lubrication of chains with medium pitch (50 to 300 mm), where speed is below 2 pitches/second.



*Modular and flexible system to project wide range of viscosity lubricants to several lubrication points (commonly up to 12).*



*A compact unit with integrated automation, pumping systems and reservoir makes installation simple and user friendly. It serves up to 8 lubrication points.*



*SKF ChainLube oil projection systems can be set up with SKF food grade chain lubricant for low temperature and humid environment or other type of lubricant used on site.*

# Reduced maintenance

SKF Power Transmission and SKF Maintenance Products together help you mount, lubricate, align and maintain your application more efficiently.

## Chain drives

By using high quality steel and paying careful attention to the smallest details in the manufacturing process, SKF chains are built for endurance. Specialized chains, such as the Dacrotized chain, can run longer, even in the most corrosive environments.

## Pinpoint accurate shaft alignment simply achieved

The SKF shaft alignment tools, TKSA series, offer you simplicity with a high degree of accuracy.

## Measuring, aligning and documenting.

These highly innovative tools feature a three-step process for correct alignment. First, measure the machinery's current alignment status. Then, align the machine vertically and horizontally. Finally, document and keep track of the alignment activities.



## Features

- Easy-to-use, three-step process: measure-align-document
- Compact, lightweight design
- Spirit levels allow easy and fast positioning of the measuring units
- Measurements in millimeters or inches facilitate worldwide use
- Supplied in sturdy, lightweight carrying cases for portability

## Extend your chain life with SKF oils

SKF Chain oils come in three convenient sizes to suit the needs of most chain applications in industrial environments.

The chain oils – medium temperature, high temperature and food compatible (NSF H1) – are available in 400 ml (13,52 oz.) aerosol cans, 5 liter (1,32 gallon) cans, and as an oil fill for SYSTEM 24® single point automatic lubricators.





# SKF – the knowledge engineering company

From one simple but inspired solution to a misalignment problem in a textile mill in Sweden, and fifteen employees in 1907, SKF has grown to become a global industrial knowledge leader.



Over the years we have built on our expertise in bearings, extending it to seals, mechatronics, services and lubrication systems. Our knowledge network includes 46 000 employees, 15 000 distributor partners, offices in more than 130 countries, and a growing number of SKF Solution Factory sites around the world.

## Research and development

We have hands-on experience in over forty industries, based on our employees' knowledge of real life conditions. In addition our world-leading experts and university partners who pioneer advanced theoretical research and development in areas including tribology, condition monitoring, asset management and bearing life theory. Our ongoing commitment to research and development helps us keep our customers at the forefront of their industries.

## Meeting the toughest challenges

Our network of knowledge and experience along with our understanding of how our core technologies can be combined helps us create innovative solutions that meet the toughest of challenges. We work closely with our customers throughout the asset life cycle, helping them to profitably and responsibly grow their businesses.

## Working for a sustainable future

Since 2005, SKF has worked to reduce the negative environmental impact from our own operations and those of our suppliers. Our continuing technology development introduced the SKF BeyondZero portfolio of products and services which improve efficiency and reduce energy losses, as well as enable new technologies harnessing wind, solar and ocean power. This combined approach helps reduce the environmental impact both in our own operations and in our customers'.



*SKF Solution Factory makes SKF knowledge and manufacturing expertise available locally, to provide unique solutions and services to our customers.*



*Working with SKF IT and logistics systems and application experts, SKF Authorized Distributors deliver a valuable mix of product and application knowledge to customers worldwide.*





## Our knowledge – your success

**SKF Life Cycle Management is how we combine our technology platforms and advanced services, and apply them at each stage of the asset life cycle, to help our customers to be more successful, sustainable and profitable.**

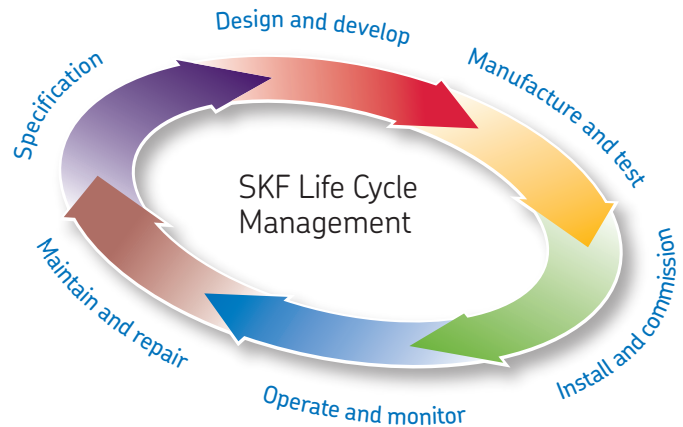

### Working closely with you

Our objective is to help our customers improve productivity, minimize maintenance, achieve higher energy and resource efficiency, and optimize designs for long service life and reliability.



### Bearings

SKF is the world leader in the design, development and manufacture of high performance rolling bearings, plain bearings, bearing units and housings.

### Innovative solutions

Whether the application is linear or rotary or a combination of the two, SKF engineers can work with you at each stage of the asset life cycle to improve machine performance by looking at the entire application. This approach doesn't just focus on individual components like bearings or seals. It looks at the whole application to see how each component interacts with the next.



### Machinery maintenance

Condition monitoring technologies and maintenance services from SKF can help minimize unplanned downtime, improve operational efficiency and reduce maintenance costs.

### Design optimization and verification

SKF can work with you to optimize current or new designs with proprietary 3-D modeling software that can also be used as a virtual test rig to confirm the integrity of the design.



### Sealing solutions

SKF offers standard seals and custom engineered sealing solutions to increase uptime, improve machine reliability, reduce friction and power losses, and extend lubricant life.



### Mechatronics

SKF fly-by-wire systems for aircraft and drive-by-wire systems for off-road, agricultural and forklift applications replace heavy, grease or oil consuming mechanical and hydraulic systems.



### Lubrication solutions

From specialized lubricants to state-of-the-art lubrication systems and lubrication management services, lubrication solutions from SKF can help to reduce lubrication related downtime and lubricant consumption.



### Actuation and motion control

With a wide assortment of products – from actuators and ball screws to profile rail guides – SKF can work with you to solve your most pressing linear system challenges.







© SKF is a registered trademark of the SKF Group.

Kevlar is a registered trademark of DuPont.

Dacromet is a registered trademark of Metal Coatings International Inc. Corporation.

© SKF Group 2013

The contents of this publication are the copyright of the publisher and may not be reproduced (even extracts) unless prior written permission is granted. Every care has been taken to ensure the accuracy of the information contained in this publication but no liability can be accepted for any loss or damage whether direct, indirect or consequential arising out of the use of the information contained herein.

**PUB PT/P1 13747 EN** · June 2013

This publication supersedes publication 6772.

Certain image(s) used under license from Shutterstock.com